



SERVICE MANUAL

UHF FM TRANSCEIVERS

IC-F4GT
IC-F4GS

INTRODUCTION

This service manual describes the latest service information for the **IC-F4GT and IC-F4GS** at the time of publication.

To upgrade quality, all electrical or mechanical parts and internal circuits are subject to change without notice or obligation.

DANGER

NEVER connect the transceiver to an AC outlet or to a DC power supply that uses more than 16 V. Such a connection could cause a fire hazard and/or electric shock.

DO NOT expose the transceiver to rain, snow or any liquids.

DO NOT reverse the polarities of the power supply when connecting the transceiver.

DO NOT apply an RF signal of more than 20 dBm (100mW) to the antenna connector. This could damage the transceiver's front end.

ORDERING PARTS

Be sure to include the following four points when ordering replacement parts:

1. 10-digit order numbers
2. Component part number and name
3. Equipment model name and unit name
4. Quantity required

<SAMPLE ORDER>

1130007610	S.IC	μPD3140GS	IC-F4GT	MAIN UNIT	1 pieces
8810009510	Screw	BT M2 x 4 NI-ZU	IC-F4GS	Chassis	10 pieces

Addresses are provided on the inside back cover for your convenience.



REPAIR NOTES

1. Make sure a problem is internal before disassembling the transceiver.
2. **DO NOT** open the transceiver until the transceiver is disconnected from its power source.
3. **DO NOT** force any of the variable components. Turn them slowly and smoothly.
4. **DO NOT** short any circuits or electronic parts. An insulated turning tool **MUST** be used for all adjustments.
5. **DO NOT** keep power ON for a long time when the transceiver is defective.
6. **DO NOT** transmit power into a signal generator or a sweep generator.
7. **ALWAYS** connect a 40 dB to 50 dB attenuator between the transceiver and a deviation meter or spectrum analyzer when using such test equipment.
8. **READ** the instructions of test equipment thoroughly before connecting equipment to the transceiver.

TABLE OF CONTENTS

SECTION 1 SPECIFICATIONS

SECTION 2 INSIDE VIEWS

SECTION 3 DISASSEMBLY AND OPTION INSTRUCTIONS

3-1	DISASSEMBLY INSTRUCTION	3-1
3-2	OPTIONAL UNIT INSTALLATIONS	3-2

SECTION 4 CIRCUIT DESCRIPTION

4-1	RECEIVER CIRCUITS	4-1
4-2	TRANSMITTER CIRCUITS	4-1
4-3	PLL CIRCUITS	4-2
4-4	POWER SUPPLY CIRCUITS	4-3
4-5	CPU PORT ALLOCATIONS	4-4

SECTION 5 ADJUSTMENT PROCEDURES

5-1	PREPARATION	5-1
5-2	PLL ADJUSTMENT	5-4
5-3	SOFTWARE ADJUSTMENT	5-5

SECTION 6 PARTS LIST

SECTION 7 MECHANICAL PARTS AND DISASSEMBLY

SECTION 8 SEMI-CONDUCTOR INFORMATION

SECTION 9 BOARD LAYOUTS

9-1	LOW BAND	9-1
9-2	440-470 MHz BAND EXCEPT W/N-TYPE	9-3
9-3	470-500 MHz AND HIGH BANDS	9-5
9-4	W/N-TYPE	9-7

SECTION 10 BC-137 OPTIONAL DESKTOP CHARGER INFORMATION

10-1	PARTS LIST	10-1
10-2	DISASSEMBLY INFORMATION	10-1
10-3	VOLTAGE DIAGRAM	10-2
10-4	BOARD LAYOUT	10-2

SECTION 11 BLOCK DIAGRAM

SECTION 12 VOLTAGE DIAGRAM

SECTION 1 SPECIFICATIONS

		ETS 300 086	EIA/TIA 603	
GENERAL	Frequency coverage	400–430 MHz, 440–470 MHz, 470–500 MHz ^{*1*} , 490–512 MHz ^{*1} , 490–520 MHz ^{*2}		
	Type of emission	16K0F3E (25 kHz: W-type), 14K0F3E (20 kHz: M-type), 8K50F3E (12.5 kHz: N-type)		
	Number of channels	100 ch (100 channel version, except ETS) 32 ch (16 channels × 2 banks: 2-BANK version), 16 ch (16 channel version)		
	Power supply requirement	7.2 V DC (negative ground; supplied battery pack)		
	Current drain (approx.)	TX	at High	1.55 A
			at Low	800 mA
		RX	rated audio	250 mA
			stand-by	70 mA
	Frequency stability	±2.0 kHz (W/M-type), ±1.5 kHz (N-type)	±0.00025%	
	Usable temperature range	–25°C to +55°C	–30°C to +60°C (–22°C to +140°C)	
Dimensions (proj. not included)	54(W) × 132(H) × 35(D) mm; 2 ⁵ / ₃₂ (W) × 5 ³ / ₁₆ (H) × 1 ³ / ₈ (D) inch			
Weight (with BP-209)	355 g; 12.5 oz			
TRANSMITTER	Output power	High 4 W Low 1 W		
	Modulation system	Variable reactance frequency modulation		
	Max. frequency deviation	±5.0 kHz (W-type), ±4.0 kHz (M-type) ^{*3} , ±2.5 kHz (N-type)		
	Spurious emissions	0.25 μW @ < 1 GHz, 1.0 μW @ < 1 GHz	73 dBc typical	
	Adjacent channel power	70 dB (W/M-type) 60 dB (N-type)	70 dB typical (25 kHz) 60 dB typical (12.5 kHz)	
	Transmitter audio distortion	Less than 5% at 1 kHz, 60% deviation	Less than 3% at 1 kHz, 40% deviation	
	Limiting charact of modulator	70–100% of max. deviation		
	Ext. microphone connector	3-conductor 2.5(d) mm (1/10")/2.2 kΩ		
RECEIVER	Receive system	Double-conversion superheterodyne system		
	Intermediate frequencies	1st: 46.350 MHz, 2nd: 450 kHz		
	Sensitivity (typical)	0.3 μV at 12 dB SINAD 0.79 μV (emf) at 20 dB SINAD	0.3 μV at 12 dB SINAD	
	Squelch sencitivity	0.3 μV typical (at threshold)		
	Adjacent channel selectivity	70 dB (W/M-type) 60 dB (N-type)	75 dB typical (W-type) 65 dB typical (N-type)	
	Spurious response	70 dB	70 dB typical	
	Intermodulation rejection ratio	65 dB	70 dB typical	
	Hum and noise	45 dB typical (W/M-type) 43 dB typical (N-type)	45 dB typical (25 kHz) 40 dB typical (12.5 kHz)	
	Audio output power (at 7.2 V DC)	500 mW typical at 5% distortion with an 8 Ω load		
	External SP connector	3-conductor 3.5(d) mm (1/8")/8 Ω		

Measurements made in accordance with EIA/TIA-152-C, 204-D, 603 or ETS 300-086.

^{*1}EIA/TIA version only, ^{*2}General version only, ^{*3}ETS/CEPT version only

All stated specifications are subject to change without notice or obligation.

SECTION 2 INSIDE VIEWS

• MAIN UNIT

TOP VIEW

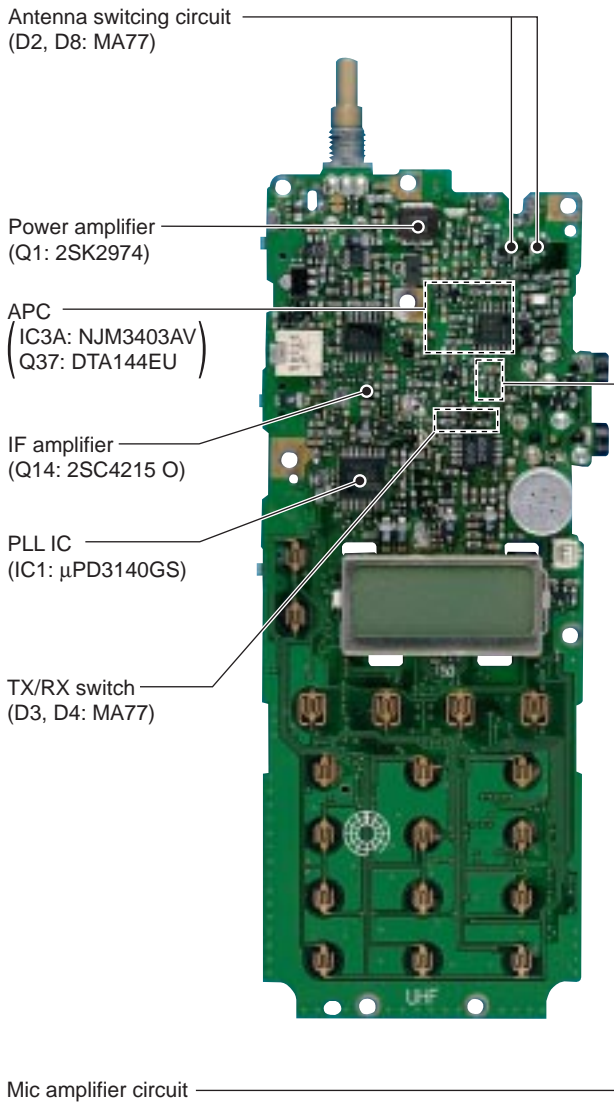

BOTTOM VIEW

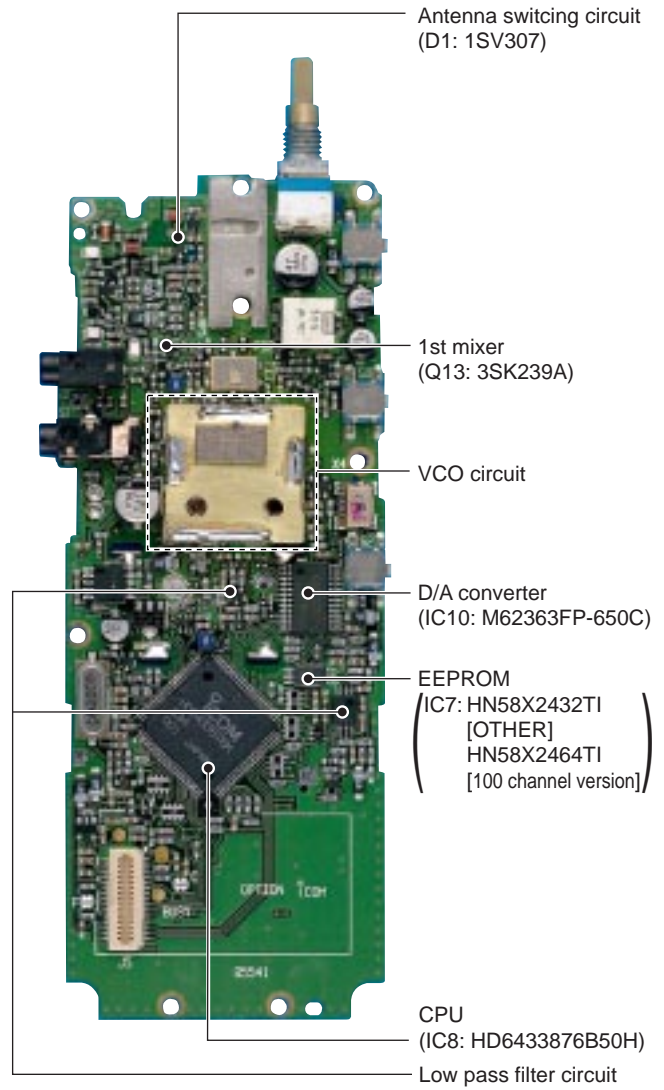

SECTION 3 DISASSEMBLY AND OPTION INSTRUCTIONS

3-1 DISASSEMBLY INSTRUCTION

• REMOVING THE CHASSIS PANEL

- ① Unscrew 1 nut (A), and remove 1 knob (B).
- ② Unscrew 2 screws (C).
- ③ Take off the chassis in the direction of the arrow.
- ④ Unplug J6 to separate front panel and chassis.

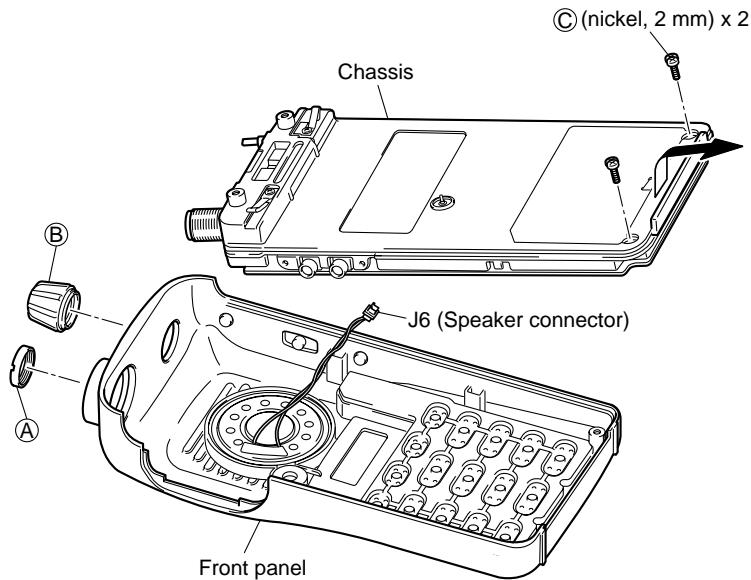

• REMOVING THE MAIN UNIT

- ① Remove the searing rubber.
- ② Unsolder 4 points (D), and unscrew 1 nut (E).
- ③ Unscrew 3 screws (F), and 6 screws (G) (silver, 2 mm) to separate the chassis and the MAIN unit.
- ④ Take off the MAIN unit in the direction of the arrow.

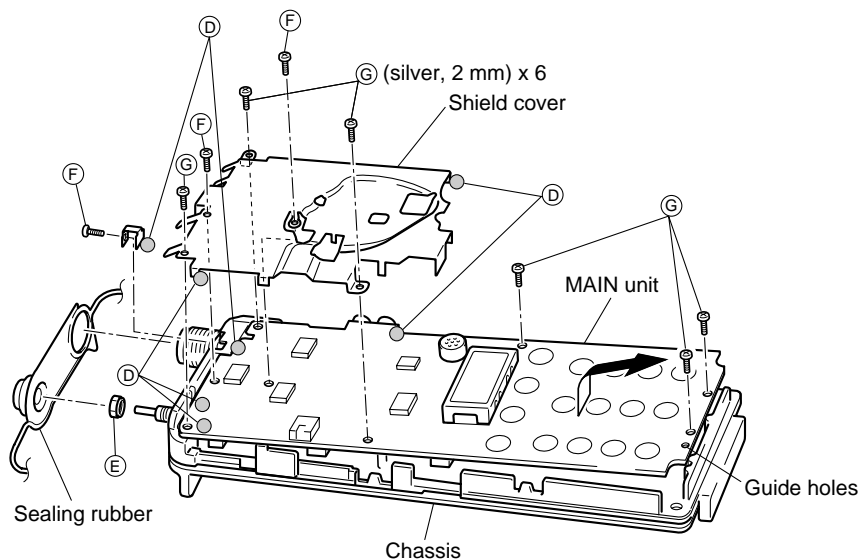

3-2 OPTIONAL UNIT INSTALLATIONS

- ① Remove the option cover.
- ② Remove the bottom protective paper of the sponge.
- ③ Connect one of UT-96, UT-105, UT-108, UT-109, UT-110, UT-111 and UT-113 optional unit to J5.
- ④ Replace the option cover to the chassis-hole.

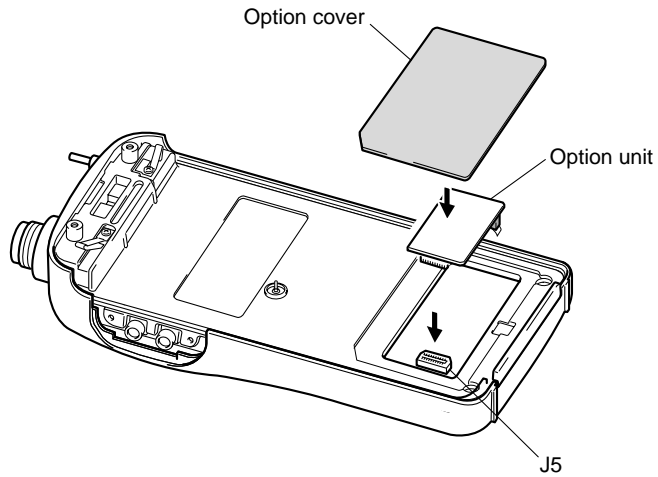

NOTE: Some optional units need to detach the sponge as shown below before installing it. Otherwise, the optional units may not install properly.

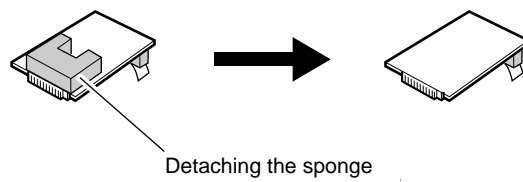

4-1-5 AF CIRCUIT

AF signals from the FM IF IC (IC2, pin 9) are applied to the mute switch (IC4, pin 1) via the AF filter circuit (IC3b, pins 6, 7). The output signals from pin 11 are applied to the AF power amplifier (IC5, pin 4) after being passed through the [VOL] control (R143).

The applied AF signals are amplified at the AF power amplifier circuit (IC5, pin 4) to obtain the specified audio level. The amplified AF signals, output from pin 10, are applied to the internal speaker (SP1) as the "SP" signal via the [SP] jack when no plug is connected to the jack.

4-1-6 SQUELCH CIRCUIT

A squelch circuit cuts out AF signals when no RF signals are received. By detecting noise components in the AF signals, the squelch switches the AF mute switch.

A portion of the AF signals from the FM IF IC (IC2, pin 9) are applied to the active filter section (IC2, pin 8) where noise components are amplified and detected with an internal noise detector.

The active filter section amplifies noise components. The filtered signals are rectified at the noise detector section and converted into "NOIS" (pulse type) signals at the noise comparator section. The "NOIS" signal is applied to the CPU (IC8, pin 19).

The CPU detects the receiving signal strength from the number of the pulses, and outputs an "RMUT" signal from pin 49. This signal controls the mute switch (IC4, pin 13) to cut the AF signal line.

4-1-7 WIDE AND NARROW SWITCHING CIRCUIT

The "NWC" signal from the CPU (IC8, pin 38) is applied to the Q41. Q41 is switched ON or OFF by the signal. Q41 controls IC2's detector output to same level both wide band mode and narrow band mode.

4-2 TRANSMITTER CIRCUITS

4-2-1 MICROPHONE AMPLIFIER CIRCUIT

The microphone amplifier circuit amplifies audio signals with +6 dB/octave pre-emphasis characteristics from the microphone to a level needed for the modulation circuit.

The AF signals from the microphone are applied to the microphone amplifier circuit (IC3c, pin 10). The amplified AF signals are passed through the low-pass filter circuit (IC3d, pins 13, 14) via the mute switch (IC4, pins 4, 3). The filtered AF signals are applied to the modulator circuit after being passed through the mute switch (IC4, pins 9, 8).

4-2-2 MODULATION CIRCUIT

The modulation circuit modulates the VCO oscillating signal (RF signal) using the microphone audio signal.

The audio signals change the reactance of a diode (D404) to modulate an oscillated signal at the VCO circuit (Q7, Q8). The oscillated signal is amplified at the buffer-amplifiers (Q4, Q6), then applied to the T/R switching circuit (D3, D4).

4-2-3 DRIVE/POWER AMPLIFIER CIRCUITS

The signal from the VCO circuit passes through the T/R switching circuit (D3) and is amplified at the buffer (Q403, Q3), pre-drive (Q2) and power amplifier (Q1) to obtain 4 W of RF power (at 7.2 V DC). The amplified signal passes through the antenna switching circuit (D1), and low-pass filter and is then applied to the antenna connector.

The bias current of the pre-drive (Q2) and the power amplifier (Q1) is controlled by the APC circuit.

4-2-5 APC CIRCUIT

The APC circuit (IC3a, Q37) protects the drive and the power amplifiers from excessive current drive, and selects HIGH or LOW output power.

• APC CIRCUIT

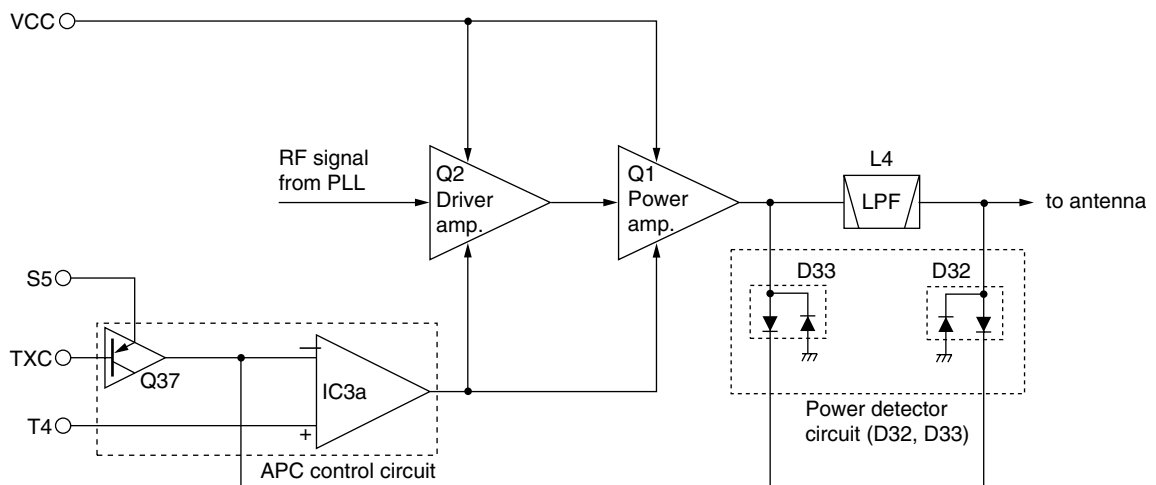

The signal output from the power detector circuit (D32, D33) is applied to the differential amplifier (IC3a, pin 2), and the "T4" signal from the expander (IC10, pin 11), controlled by the CPU (IC8), is applied to the other input for reference.

When the driving current is increased, input voltage of the differential amplifier (pin 2) will be increased. In such cases, the differential amplifier output voltage (pin 1) is decreased to reduce the driving current.

4-3 PLL CIRCUIT

A PLL circuit provides stable oscillation of the transmit frequency and receive 1st LO frequency. The PLL output compares the phase of the divided VCO frequency to the reference frequency. The PLL output frequency is controlled by the divided ratio (N-data) of a programmable divider.

The PLL circuit contains the VCO circuit (Q7, Q8). The oscillated signal is amplified at the buffer-amplifiers (Q6, Q5) and then applied to the PLL IC (IC1, pin 2).

The PLL IC contains a prescaler, programmable counter, programmable divider and phase detector, etc. The entered signal is divided at the prescaler and programmable counter section by the N-data ratio from the CPU. The divided signal is detected on phase at the phase detector using the reference frequency.

If the oscillated signal drifts, its phase changes from that of the reference frequency, causing a lock voltage change to compensate for the drift in the oscillated frequency.

A portion of the VCO signal is amplified at the buffer-amplifier (Q4), and is then applied to the receive 1st mixer (Q13) or transmit buffer-amplifier circuit (Q403) via the T/R switching diode (D3, D4).

• PLL CIRCUIT

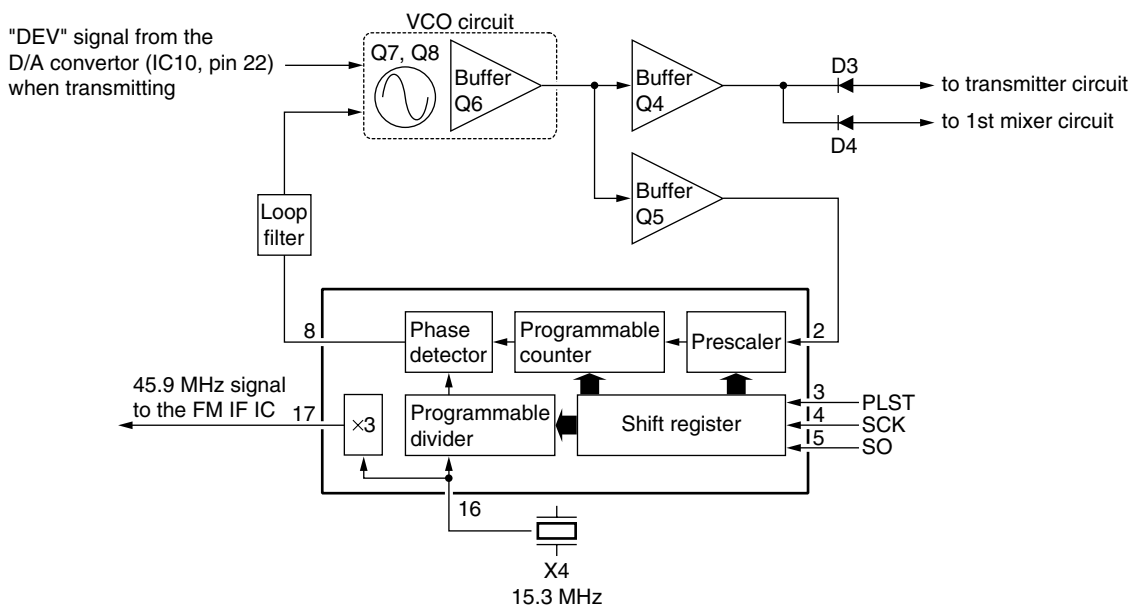

4-4 POWER SUPPLY CIRCUITS

VOLTAGE LINE

LINE	DESCRIPTION
HV	The voltage from the attached battery pack.
VCC	The same voltage as the HV line (battery voltage) which is controlled by the power switch ([VOL] control).
CPU5	Common 5 V converted from the VCC line by the reference regulator circuit (IC6). The output voltage is applied to the CPU (IC8), the 5 V regulator controller (Q20), reset circuit (IC11) and etc.
T5	5 V for transmitter circuits regulated by the T5 regulator circuit (Q22). The output voltage is applied to the low-pass filter (Q35), buffer amplifiers (Q403, Q3) and etc.
R5	5 V for receiver circuits regulated by the R5 regulator circuit (Q21). The output voltage is applied to the low-pass filter (IC12), analog switch (IC4), 1st mixer (Q13), RF amplifier (Q12), and etc.
S5	Common 5 V converted from the VCC line by the S5 regulator circuit (Q18, Q19). The output voltage is applied to the buffer amplifier (Q36), APC circuit (IC3A, Q37), and etc.
OPT	The same voltage as the CPU5 line for the optional HM-46L, HM-75A or HS-51 through a resistor (R132).

4-5 PORT ALLOCATIONS

4-5-1 CPU (IC8)

Pin number	Port name	Description
1	VIN	Input port for battery voltage detection.
9	RESET	Input port for RESET signal.
11	CSIFT	Outputs reference oscillator for the CPU control signal.
12	SCK	Outputs clock signal to the PLL IC (IC1), EEPROM (IC7), etc.
15	DAST	<ul style="list-style-type: none"> • Outputs strobe signals to the expander IC (IC10, pin 6). • Input port for the initial version signal.
16	CLIN	Input port for the cloning signal.
17	CLOUT	Outputs the cloning signal.
18	PLST	Outputs strobe signals to the PLL IC (IC1, pin 3).
19	NOIS	Input for noise signals (pulse type).
21	BUSY	Outputs BUSY detection. Low: The channel is busy.
26, 36, 37	OPV1-3	Input port for the optional unit detection signal from J5.
38	NWC	Outputs Wide/Narrow mode control signal. High: Wide mode is selected.
44-47	KR3-KR0	Output ports for key matrix. Low: When the key is pushed.
49	RMUT	<ul style="list-style-type: none"> • Outputs RX mute control signal. • Input port for the RX mute signal from optional units.
50	MMUT	<ul style="list-style-type: none"> • Output TX mute control signal. • Input port for the TX mute signal from optional units.
51	DUSE	Outputs low-pass filter cut-off frequency control signal when DTCS is activated.
52	S5C	Outputs S5 regulator control signal. Low: While power is ON.
53	R5C	Outputs R5 regulator control signal. Low: While receiving.
54	T5C	Outputs T5 regulator control signal. Low: While transmitting.
55	TXC	Outputs APC circuit control signal. High: While transmitting.
56	AFON	Outputs control signal for the regulator circuit of AF power amplifier. High: When squelch is open, etc.
57	LIGT	Outputs LCD backlight control signal. High: Lights ON.
58	ESCK	Outputs EEPROM (IC7, pin 6) clock signal.
59	ESDA	I/O port for data signals from/to EEPROM (IC7, pin 5)

CPU (IC8)—continued

Pin number	Port name	Description
63	UNLK	Input port for unlock signal. High: PLL is unlocked. Low: PLL is locked.
90	MTONE	Output port for: Beep audio while receiving. 2/5-tone signals while transmitting.
91	DTMF	Outputs DTMF tone signal while transmitting.
94	CTCIN	CTCSS/DTCS signals input port for decoding.
95	PTT	Input port for the [PTT] switch. High: While [PTT] switch is pushed.
96	BDET	Input port for the battery's type detection.
97	REMO	Input port for the remote-control signal from external MIC (HM-75).
98	SD	Input port for the RSSI detection.
99	LVIN	Input port for the PLL lock voltage.
100	TEMP	Input port for the transceiver's internal temperature detection.

4-5-2 OUTPUT EXPANDER IC (IC10)

Pin number	Port name	Description
2, 3, 10, 11	T1-T4	Output tunable bandpass filter control signals.
6	DAST	Input port for strobe signal from the CPU (IC8, pin 15).
7	SCK	Input port for clock signal from the CPU (IC8, pin 12).

SECTION 5 ADJUSTMENT PROCEDURES

5-1 PREPARATION

When you adjust the contents on page 5-5 or 5-6, SOFTWARE ADJUSTMENT, the optional CS-F3G ADJ ADJUSTMENT SOFTWARE (Rev. 2.0 or later), OPC-478 CLONING CABLE and a JIG CABLE (see illustration at page 5-2) are required.

■ REQUIRED TEST EQUIPMENT

EQUIPMENT	GRADE AND RANGE	EQUIPMENT	GRADE AND RANGE
DC power supply	Output voltage : 7.2 V DC Current capacity : 5 A or more	Audio generator	Frequency range : 300–3000 Hz Output level : 1–500 mV
RF power meter (terminated type)	Measuring range : 1–10 W Frequency range : 300–600 MHz Impedance : 50 Ω SWR : Less than 1.2 : 1	Attenuator	Power attenuation : 40 or 50 dB Capacity : 10 W or more
Frequency counter	Frequency range : 0.1–600 MHz Frequency accuracy : ±1 ppm or better Sensitivity : 100 mV or better	Standard signal generator (SSG)	Frequency range : 120–600 MHz Output level : 0.1 μV–32 mV (–127 to –17 dBm)
FM deviation meter	Frequency range : DC–600 MHz Measuring range : 0 to ±5 kHz	DC voltmeter	Input impedance : 50 kΩ/V DC or better
Digital multimeter	Input impedance : 10 MΩ/V DC or better	Oscilloscope	Frequency range : DC–20 MHz Measuring range : 0.01–20 V
		AC millivoltmeter	Measuring range : 10 mV–10 V

■ SYSTEM REQUIREMENTS

- IBM PC compatible computer with an RS -232C serial port (38400 bps or faster)
- Microsoft Windows 95 or Windows 98
- Intel i486DX processor or faster (Pentium 100 MHz or faster recommended)
- At least 16 MB RAM and 10 MB of hard disk space
- 640×480 pixel display (800×600 pixel display recommended)

■ ADJUSTMENT SOFTWARE INSTALLATION

- ① Boot up Windows.
 - Quit all applications when Windows is running.
- ② Insert the cloning software CD-ROM into the appropriate CD-ROM drive.
- ③ Select 'Run' from the [Start] menu.
- ④ Type the setup program name using the full path name, then push the [Enter] key. (For example; D:\ setup)
- ⑤ Follow the prompts.
- ⑥ Program group 'CS-F3G ADJ' appears in the 'Programs' folder of the [Start] menu.

■ STARTING SOFTWARE ADJUSTMENT

- ① Connect IC-F4GT/GS and PC with the optional OPC-478 and the JIG cable.
- ② Boot up Windows, and turn the transceiver power ON.
- ③ Click the program group 'CS-F3G ADJ' in the 'Programs' folder of the [Start] menu, then CS-F3G ADJ's window is appeared.
- ④ Click the TCXO tag.
- ⑤ Click 'Connect' on the CS-F3G's window, then appears IC-F4GT/GS's up-to-date condition.
- ⑥ Set or modify adjustment data as desired.

IBM is a registered trademark of International Business Machines Corporation in the U.S.A. and other countries. Microsoft and Windows are registered trademarks of Microsoft Corporation in the U.S.A. and other countries. Screen shots produced with permission from Microsoft Corporation. All other products or brands are registered trademarks or trademarks of their respective holders.

• SCREEN DISPLAY EXAMPLE

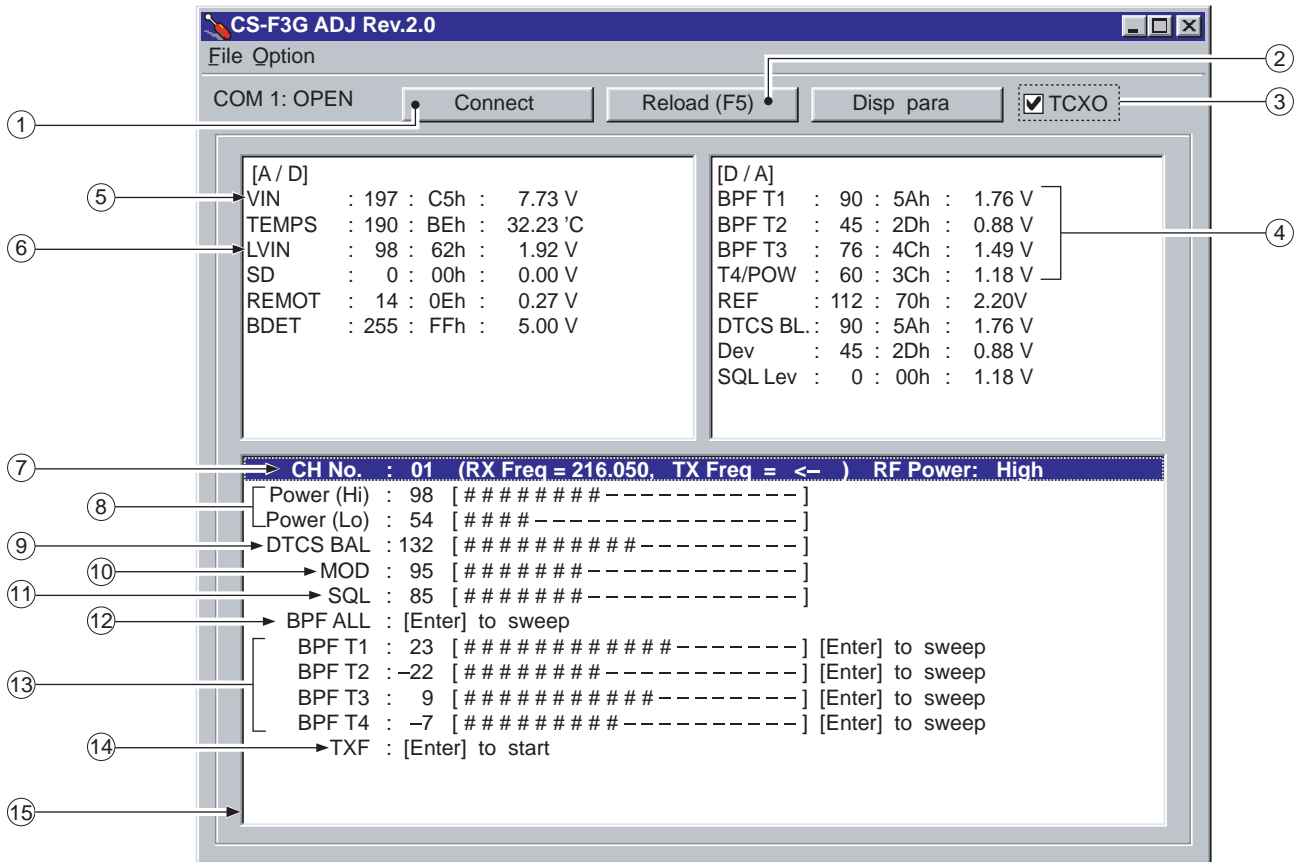

NOTE: The above values for settings are example only.
Each transceiver has its own specific values for each setting.

- | | |
|--|---|
| ① : Transceiver's connection state | ⑨ : DTCS wave balance |
| ② : Reload adjustment data | ⑩ : FM deviation |
| ③ : TCXO tag (must check for F4G adjustment) | ⑪ : Squelch level |
| ④ : Receive sensitivity measurement | ⑫ : Receive sensitivity (automatically) |
| ⑤ : Connected DC voltage | ⑬ : Receive sensitivity (manually) |
| ⑥ : PLL lock voltage | ⑭ : Reference frequency |
| ⑦ : Operating channel select | ⑮ : Adjustment items |
| ⑧ : RF output power | |

• JIG CABLE

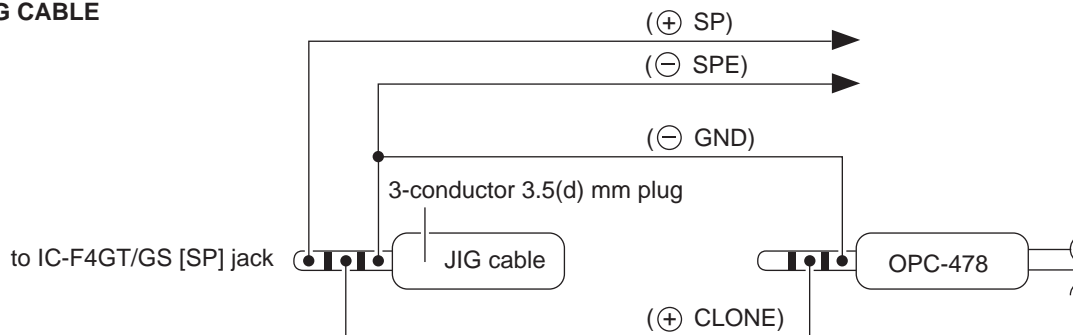

• CONNECTION

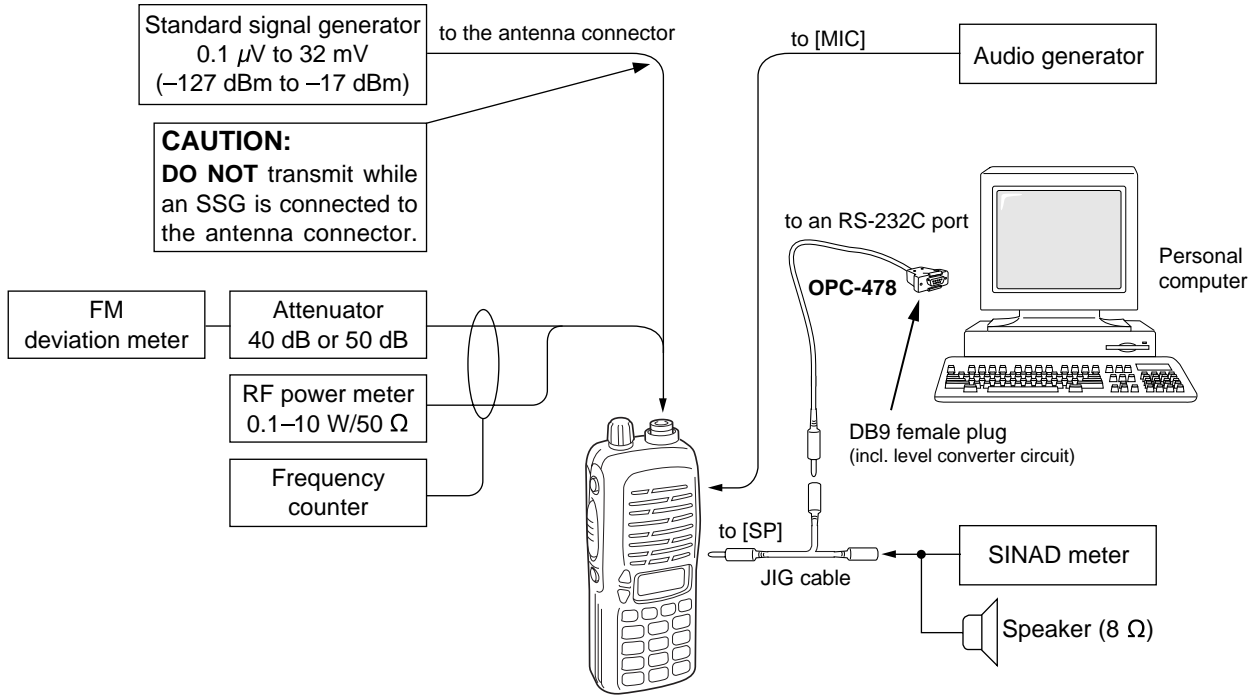

• DC POWER CABLE CONNECTIONS

SOFTWARE ADJUSTMENT

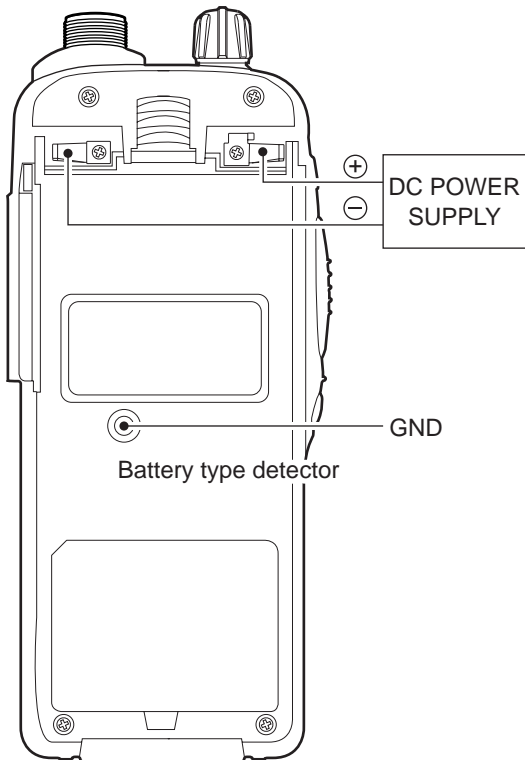

PLL ADJUSTMENT

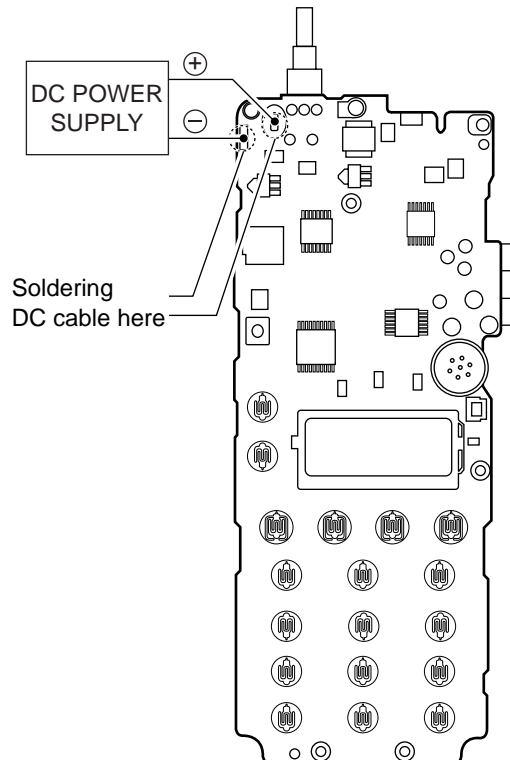

Top view

NOTE: When you adjust the output power (high power), the battery type detector must be connected to GND (see illustration at above). Otherwise the transceiver does not transmit high power, the output power will be low.

5-2 PLL ADJUSTMENT

ADJUSTMENT	ADJUSTMENT CONDITIONS	MEASUREMENT		VALUE	ADJUSTMENT		
		UNIT	LOCATION		UNIT	ADJUST	
PLL LOCK VOLTAGE	1 • Operating frequency: 400.000 MHz (A) 440.000 MHz (B) 470.000 MHz (C) 490.000 MHz (D, E) • Receiving	MAIN	Connect a digital multi meter to check point LV.	1.3 V	MAIN	L11	
	2 • Transmitting					1.3 V (B) 1.05 V (except B)	L405
	3 • Operating frequency: 430.000 MHz (A) 470.000 MHz (B) 500.000 MHz (C) 512.000 MHz (D) 520.000 MHz (E) • Receiving					3.0–4.5 V (A, B, C) 2.0–3.7 V (D) 2.5–4.2 V (E)	Verify
	4 • Transmitting					3.0–4.5 V (A, C) 2.7–4.2 V (B) 2.0–3.7 V (D) 2.5–4.2 V (E)	

(A): 400–430 MHz

(B): 440–470 MHz

(C): 470–500 MHz

(D): 490–512 MHz

(E): 490–520 MHz

(N): N-type

(W): W-type

(M): M-type

• MAIN UNIT

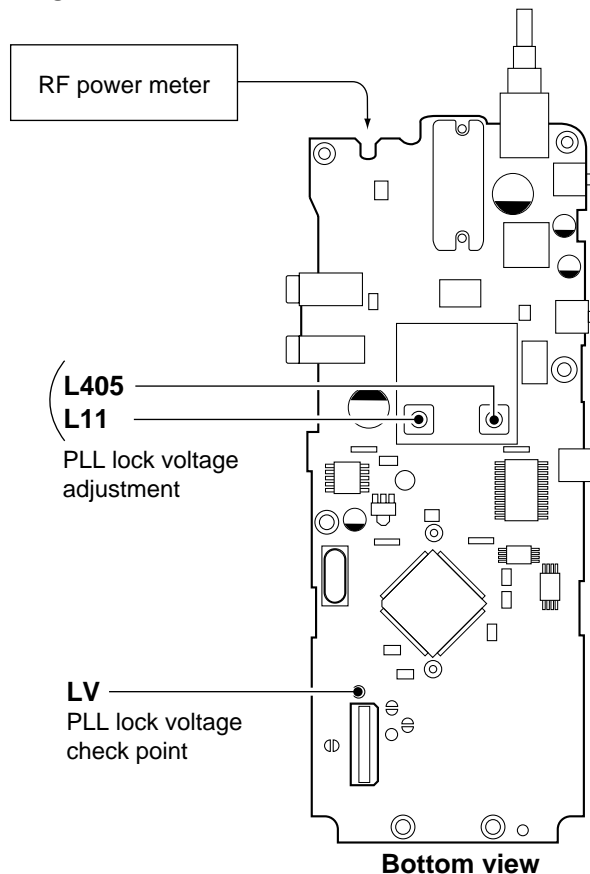

5-3 SOFTWARE ADJUSTMENT

Select an operation using [↑] / [↓] keys, then set specified value using [←] / [→] keys on the connected computer keyboard.

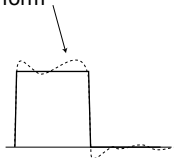
ADJUSTMENT	ADJUSTMENT CONDITION	MEASUREMENT		VALUE
		UNIT	LOCATION	
REFERENCE FREQUENCY [TXF]	1 <ul style="list-style-type: none"> Operating frequency: <ul style="list-style-type: none"> 400.000 MHz (A) 440.000 MHz (B) 470.000 MHz (C) 490.000 MHz (D), (E) High/Low switch : Low Connect the RF power meter or 50 Ω dummy load to the antenna connector. Transmitting 	Top panel	Loosely couple a frequency counter to the antenna connector.	400.0000 MHz (A) 440.0000 MHz (B) 470.0000 MHz (C) 490.0000 MHz (D), (E)
OUTPUT POWER [POWER(LO)]	1 <ul style="list-style-type: none"> Operating frequency: <ul style="list-style-type: none"> 415.000 MHz [EUR] of (A) 430.000 MHz [OTHER] of (A) 455.000 MHz [EUR] of (B) 470.000 MHz [OTHER] of (B) 500.000 MHz (C) 512.000 MHz (D) 520.000 MHz (E) High/Low switch : Low Transmitting 	Top panel	Connect an RF power meter to the antenna connector.	1.0 W
[POWER(HI)]	2 <ul style="list-style-type: none"> High/Low switch : High Transmitting 			4.0 W
FM DEVIATION [MOD]	1 <ul style="list-style-type: none"> Operating frequency: <ul style="list-style-type: none"> 400.000 MHz (A) 440.000 MHz (B) 470.000 MHz (C) 490.000 MHz (D), (E) High/Low switch : Low Connect the audio generator to the [MIC] jack and set as: <ul style="list-style-type: none"> 1.0 kHz/150 mVrms Set the FM deviation meter as: <ul style="list-style-type: none"> HPF : OFF LPF : 20 kHz De-emphasis : OFF Detector : (P-P)/2 Transmitting 	Top panel	Connect an FM deviation meter to the antenna connector through the attenuator.	±3.9 kHz*1 (W) ±3.2 kHz (M) ±1.95 kHz*2 (N)
DTCS WAVE FORM [DTCS BAL]	1 <ul style="list-style-type: none"> Operating frequency: <ul style="list-style-type: none"> 430.000 MHz (A) 470.000 MHz (B) 500.000 MHz (C) 512.000 MHz (D) 520.000 MHz (E) High/Low switch : Low No audio applied to the [MIC] jack. DTCS code : 007 Transmitting 	Top panel	Connect an FM deviation meter with an oscilloscope to the antenna connector through an attenuator.	Set to flat wave form 

*1, *2 W/N-type must be adjusted both *1 and *2 on the FM DEVIATION ADJUSTMENT.

(A): 400–430 MHz

(B): 440–470 MHz

(C): 470–500 MHz

(D): 490–512 MHz

(E): 490–520 MHz

(N): N-type

(W): W-type

(M): M-type

SOFTWARE ADJUSTMENT – continued

Select an operation using [↑] / [↓] keys, then set specified value using [←] / [→] keys on the connected computer keyboard.

ADJUSTMENT	ADJUSTMENT CONDITION	MEASUREMENT		VALUE	
		UNIT	LOCATION		
RX SENSITIVITY [BPF T1] – [BPF T4]	1	<ul style="list-style-type: none"> Operating frequency: <ul style="list-style-type: none"> 400.000 MHz A 440.000 MHz B 470.000 MHz C 490.000 MHz D, E Connect a standard signal generator to the antenna connector and set as: <ul style="list-style-type: none"> Frequency : 400.000 MHz A 440.000 MHz B 470.000 MHz C 490.000 MHz D, E Level : 10 μV* (–87 dBm) Modulation : 1 kHz Deviation : \pm3.5 kHz*¹ W \pm2.8 kHz M \pm1.75 kHz*² N Receiving 	Top panel	Connect a SINAD meter with an 8 Ω load to the [SP] jack.	Minimum distortion level
	<p>CONVENIENT: The BPF T1–BPF T4 can be adjusted automatically.</p> <p>①-1: Set the cursor to “BPF ALL” on the adjustment program and then push [ENTER] key.</p> <p>①-2: The connected PC tunes BPF T1–BPF T4 to peak levels.</p> <p>or</p> <p>②-1: Set the cursor to one of BPF T1, T2, T3, or T4 as desired.</p> <p>②-2: Push [ENTER] key to start tuning.</p> <p>②-3: Repeat ②-1 and ②-2 to perform additional BPF tuning.</p>				
SQUELCH LEVEL [SQL]	1	<ul style="list-style-type: none"> Operating frequency: <ul style="list-style-type: none"> 400.000 MHz A 440.000 MHz B 470.000 MHz C 490.000 MHz D, E Connect a standard signal generator to the antenna connector and set as: <ul style="list-style-type: none"> Frequency : 400.000 MHz A 440.000 MHz B 470.000 MHz C 490.000 MHz D, E Level : 0.2 μV* (–121 dBm) Modulation : 1 kHz Deviation : \pm3.5 kHz*¹ W \pm2.8 kHz M \pm1.75 kHz*² N Receiving 	Top panel	Connect a SINAD meter with an 8 Ω load to the [SP] jack.	12 dB SINAD
	2	<ul style="list-style-type: none"> Receiving 			At the point where the audio signals just appears.

*The output level of the standard signal generator (SSG) is indicated as the SSG's open circuit.

*1, *2 W/N-type must be set the standard signal generator deviation level both *1 and *2 on the RX SENSITIVITY AND SQUELCH LEVEL ADJUSTMENTS.

A: 400–430 MHz

B: 440–470 MHz

C: 470–500 MHz

D: 490–512 MHz

E: 490–520 MHz

N: N-type

W: W-type

M: M-type

SECTION 6 PARTS LIST

[MAIN UNIT]

REF NO.	ORDER NO.	DESCRIPTION		
IC1	1130007610	S.IC	μPD3140GS-E1 (DS8)	
IC2	1110003490	S.IC	TA31136FN (D,EL)	
IC3	1110005140	S.IC	NJM3403AV-TE1	
IC4	1130008090	S.IC	BU4066BCFV-E1	
IC5	1110001810	S.IC	TA7368F (TP1)	
IC6	1110005350	S.IC	NJM2870F05-TE1	Ⓓ
	1180001740	S.IC	TK11250BMCL	[OTHER]
IC7	1130009680	S.IC	HN58X2432TI	[OTHER]
	1140008650	S.IC	HN58X2464TI	⓪
IC8	1140010000	S.IC	HD6433876B50H	
IC10	1190000350	S.IC	M62363FP-650C	
IC11	1130009110	S.IC	S-80942ANMP-DD6-T2	
IC12	1110003800	S.IC	NJM2904V-TE1	
IC13	1110002750	S.IC	TA75S01F (TE85R)	
IC14	1130007020	S.IC	TC7S66FU (TE85R)	
IC15	1130007020	S.IC	TC7S66FU (TE85R)	Ⓓ only
Q1	1560001050	S.FET	2SK2974	
Q2	1560001020	S.FET	2SK2973 (MTS101P)	
Q3	1530002620	S.TRANSISTOR	2SC3585 R44-T2B	
Q4	1530003310	S.TRANSISTOR	2SC5107-O (TE85R)	
Q5	1530003310	S.TRANSISTOR	2SC5107-O (TE85R)	
Q6	1530003310	S.TRANSISTOR	2SC5107-O (TE85R)	
Q7	1530003230	S.TRANSISTOR	2SC5085-Y (TE85R)	
Q8	1530003230	S.TRANSISTOR	2SC5085-Y (TE85R)	
Q10	1530002690	S.TRANSISTOR	2SC4116-GR (TE85R)	
Q11	1590001190	S.TRANSISTOR	XP6501-(TX) .AB	
Q12	1580000720	S.FET	3SK239AXRTL	
Q13	1580000720	S.FET	3SK239AXRTL	
Q14	1530002600	S.TRANSISTOR	2SC4215-O (TE85R)	
Q15	1520000460	S.TRANSISTOR	2SB1132 T100 R	
Q16	1590001190	S.TRANSISTOR	XP6501-(TX) .AB	
Q17	1590002530	S.TRANSISTOR	UN911H (TX)	
Q18	1520000460	S.TRANSISTOR	2SB1132 T100 R	
Q19	1590001190	S.TRANSISTOR	XP6501-(TX) .AB	
Q20	1590000720	S.TRANSISTOR	DTA144EUA T106	
Q21	1510000920	S.TRANSISTOR	2SA1577 T107 Q	
Q22	1510000920	S.TRANSISTOR	2SA1577 T107 Q	
Q25	1530002690	S.TRANSISTOR	2SC4116-GR (TE85R)	
Q31	1590000660	S.TRANSISTOR	DTC144TU T107	
Q34	1560000540	S.FET	2SK880-Y (TE85R)	
Q35	1530002690	S.TRANSISTOR	2SC4116-GR (TE85R)	
Q36	1530002690	S.TRANSISTOR	2SC4116-GR (TE85R)	
Q37	1590000720	S.TRANSISTOR	DTA144EUA T106	
Q38	1590001940	S.TRANSISTOR	DTC144EE TL	
Q41	1530002690	S.TRANSISTOR	2SC4116-GR (TE85R)	Ⓓ only
Q42	1590000430	S.TRANSISTOR	DTC144EUA T106	Ⓓ only
Q401	1590001400	S.TRANSISTOR	XP1214 (TX)	
Q402	1590000430	S.TRANSISTOR	DTC144EUA T106	
Q403	1530003310	S.TRANSISTOR	2SC5107-O (TE85R)	
Q405	1590001770	S.TRANSISTOR	XP1213 (TX)	
D1	1750000580	S.DIODE	1SV307 (TPH3)	
D2	1790000620	S.DIODE	MA77 (TX)	
D3	1790000620	S.DIODE	MA77 (TX)	
D4	1790000620	S.DIODE	MA77 (TX)	
D5	1720000780	S.VARICAP	HVU350B TRF	
D8	1790000620	S.DIODE	MA77 (TX)	
D10	1720000780	S.VARICAP	HVU350B TRF	
D11	1720000780	S.VARICAP	HVU350B TRF	
D12	1720000780	S.VARICAP	HVU350B TRF	
D14	1790000620	S.DIODE	MA77 (TX)	
D26	1160000070	S.DIODE	DAN202K T146	
D27	1790001670	S.DIODE	RB706F-40T106	
D29	1730002260	S.ZENER	MA8030-H (TX)	
D32	1790001670	S.DIODE	RB706F-40T106	
D33	1790001670	S.DIODE	RB706F-40T106	
D401	1720000780	S.VARICAP	HVU350B TRF	

[MAIN UNIT]

REF NO.	ORDER NO.	DESCRIPTION		
D403	1720000780	S.VARICAP	HVU350B TRF	
D404	1720000400	S.VARICAP	1SV245 (TPH3)	
FI1	2010002450	S.XTAL	FL-313 (46.35 MHz)	Ⓐ
	2010002500	S.XTAL	FL-321 (46.350MHZ)	Ⓒ
	2030000150	S.MONOLITH	FL-335 (46.350 MHz)	Ⓜ
	2030000160	S.MONOLITH	FL-336 (46.350 MHz)	[OTHER]
FI2	2020001080	S.CERAMIC	SFPC450G-TC01	Ⓐ
	2020001490	S.CERAMIC	SFPC450E-TC01	[OTHER]
	2020001930	S.CERAMIC	CFWC450F	Ⓓ
X2	6050010870	S.XTAL	CR-663 (9.200 MHz)	
X3	6070000190	S.DISCRIMINATOR	CDBC450CX24	
X4	6050010930	S.XTAL	CR-662 (15.3 MHz)	
L1	6200008240	S.COIL	0.30-0.9-5TL 14N	Ⓔ
	6200008250	S.COIL	0.30-0.9-7TL 21N	Ⓕ
	6200009710	S.COIL	0.30-0.9-4TL 10.5N	Ⓐ, Ⓒ
L2	6200008240	S.COIL	0.30-0.9-5TL 14N	Ⓔ
	6200008250	S.COIL	0.30-0.9-7TL 21N	Ⓕ
	6200009710	S.COIL	0.30-0.9-4TL 10.5N	Ⓐ, Ⓒ
L4	6200008240	S.COIL	0.30-0.9-5TL 14N	Ⓔ
	6200008540	S.COIL	0.26-0.9-6TR 19N	Ⓕ
	6200009710	S.COIL	0.30-0.9-4TL 10.5N	Ⓐ, Ⓒ
L7	6200005660	S.COIL	ELJRE 10NG-F	Ⓒ
	6200005670	S.COIL	ELJRE 12NG-F	Ⓐ
	6200005680	S.COIL	ELJRE 15NG-F	Ⓕ
	6200005690	S.COIL	ELJRE 18NG-F	Ⓖ
	6200005700	S.COIL	ELJRE 22NG-F	Ⓕ
L8	6200005700	S.COIL	ELJRE 22NG-F	Ⓐ, Ⓒ
	6200005710	S.COIL	ELJRE 27NG-F	Ⓔ, Ⓕ
L9	6200005700	S.COIL	ELJRE 22NG-F	Ⓒ
	6200005710	S.COIL	ELJRE 27NG-F	[OTHER]
L11	6200003690	S.COIL	MC152-E558ANA-100051=P3	Ⓕ
	6200004110	S.COIL	MC152-E558ANA-100050	[OTHER]
L12	6200003550	S.COIL	MLF1608A 4R7K-T	
L13	6200003960	S.COIL	MLF1608A 1R0K-T	
L14	6200005680	S.COIL	ELJRE 15NG-F	
L15	6200008240	S.COIL	0.30-0.9-5TL 14N	
L17	6200008440	S.COIL	LQN21A 8N2D04	
L18	6200008440	S.COIL	LQN21A 8N2D04	
L19	6200008440	S.COIL	LQN21A 8N2D04	
L20	6200002850	S.COIL	NL 252018T-R82J	
L21	6200005700	S.COIL	ELJRE 22NG-F	Ⓒ
	6200005710	S.COIL	ELJRE 27NG-F	Ⓐ
	6200005720	S.COIL	ELJRE 33NG-F	Ⓔ
	6200005730	S.COIL	ELJRE 39NG-F	Ⓕ
L22	6200007680	S.COIL	LQN21A 12NJ04	Ⓐ
	6200008240	S.COIL	0.30-0.9-5TL 14N	[OTHER]
L24	6200009250	S.COIL	LQW1608A R22G00	
L25	6200004480	S.COIL	MLF1608D R82K-T	
L26	6200003590	S.COIL	EXCCL3225U1	
L31	6200008520	S.COIL	0.30-0.7-3TR 4.9N	[OTHER]
	6200008720	S.COIL	0.30-0.8-3TL 6N	Ⓕ
	6200009110	S.COIL	0.30-0.9-2TR 4.1N	Ⓒ
L33	6200009210	S.COIL	NL 252018T-390J	
L402	6200008440	S.COIL	LQN21A 8N2D04	
L404	6200004660	S.COIL	MLF1608A 1R8K-T	except Ⓔ, Ⓐ
L405	6200004110	S.COIL	MC152-E558ANA-100050	
L406	6200004660	S.COIL	MLF1608A 1R8K-T	
L407	6200003550	S.COIL	MLF1608A 4R7K-T	
L411	6200005700	S.COIL	ELJRE 22NG-F	[OTHER]
	6200005710	S.COIL	ELJRE 27NG-F	Ⓕ

S.=Surface mount

- Ⓐ: L-band of ETS/CEPT version Ⓑ: L-band Ⓒ: H-band Ⓓ: W/N-type Ⓔ: M1 (440-470 MHz)-band
 Ⓕ: M1-band of [GEN] and EIA/TIA version Ⓖ: W-type of [GEN] Ⓗ: W-type Ⓜ: N-type Ⓝ: M2 (470-500 MHz)-band
 Ⓖ: M1-band of ETS/CEPT version Ⓖ: N-type of [GEN] and EIA/TIA version Ⓜ: N-type of ETS/CEPT version
 Ⓝ: M1-band except W/N-type Ⓝ: 100 channel version Ⓟ: M (20 kHz)-type

[MAIN UNIT]

REF NO.	ORDER NO.		DESCRIPTION
L441	6200003960	S.COIL	MLF1608A 1R0K-T
L442	6200004720	S.COIL	MLF1608D R10K-T
L443	6200006190	S.COIL	BLM21P300S
R1	7030003670	S.RESISTOR	ERJ3GEYJ 823 V (82 kΩ)
R2	7030003580	S.RESISTOR	ERJ3GEYJ 153 V (15 kΩ)
R3	7030003580	S.RESISTOR	ERJ3GEYJ 153 V (15 kΩ)
R7	7030004980	S.RESISTOR	ERJ2GEJ 101 X (100 Ω)
R9	7030005050	S.RESISTOR	ERJ2GEJ 103 X (10 kΩ)
R12	7030005040	S.RESISTOR	ERJ2GEJ 472 X (4.7 kΩ)
R13	7030005530	S.RESISTOR	ERJ2GEJ 100 X (10 Ω)
R14	7030003320	S.RESISTOR	ERJ3GEYJ 101 V (100 Ω)
R15	7030005050	S.RESISTOR	ERJ2GEJ 103 X (10 kΩ)
R17	7030005040	S.RESISTOR	ERJ2GEJ 472 X (4.7 kΩ)
R18	7030003640	S.RESISTOR	ERJ3GEYJ 473 V (47 kΩ)
R19	7030004980	S.RESISTOR	ERJ2GEJ 101 X (100 Ω)
R20	7030003660	S.RESISTOR	ERJ3GEYJ 683 V (68 kΩ)
R21	7030003360	S.RESISTOR	ERJ3GEYJ 221 V (220 Ω)
R22	7030003660	S.RESISTOR	ERJ3GEYJ 683 V (68 kΩ)
R23	7030003320	S.RESISTOR	ERJ3GEYJ 101 V (100 Ω)
R30	7030003480	S.RESISTOR	ERJ3GEYJ 222 V (2.2 kΩ)
R32	7030003540	S.RESISTOR	ERJ3GEYJ 682 V (6.8 kΩ)
R33	7030008410	S.RESISTOR	ERJ2GEJ 392 X (3.9 kΩ)
R34	7030005120	S.RESISTOR	ERJ2GEJ 102 X (1 kΩ)
R41	7030004970	S.RESISTOR	ERJ2GEJ 470 X (47 Ω)
R44	7030003550	S.RESISTOR	ERJ3GEYJ 822 V (8.2 kΩ) [OTHER]
	7030003560	S.RESISTOR	ERJ3GEYJ 103 V (10 kΩ) (H)
R48	7030005090	S.RESISTOR	ERJ2GEJ 104 X (100 kΩ)
R49	7030003630	S.RESISTOR	ERJ3GEYJ 393 V (39 kΩ)
R50	7030003750	S.RESISTOR	ERJ3GEYJ 394 V (390 kΩ)
R51	7030003760	S.RESISTOR	ERJ3GEYJ 474 V (470 kΩ)
R52	7030003700	S.RESISTOR	ERJ3GEYJ 154 V (150 kΩ)
R53	7030003560	S.RESISTOR	ERJ3GEYJ 103 V (10 kΩ)
R54	7030003700	S.RESISTOR	ERJ3GEYJ 154 V (150 kΩ)
R55	7030003440	S.RESISTOR	ERJ3GEYJ 102 V (1 kΩ)
R59	7030003340	S.RESISTOR	ERJ3GEYJ 151 V (150 Ω)
R61	7030003280	S.RESISTOR	ERJ3GEYJ 470 V (47 Ω)
R62	7030003720	S.RESISTOR	ERJ3GEYJ 224 V (220 kΩ)
R63	7030003560	S.RESISTOR	ERJ3GEYJ 103 V (10 kΩ)
R64	7030003720	S.RESISTOR	ERJ3GEYJ 224 V (220 kΩ)
R65	7030005050	S.RESISTOR	ERJ2GEJ 103 X (10 kΩ)
R66	7030003700	S.RESISTOR	ERJ3GEYJ 154 V (150 kΩ)
R67	7030003560	S.RESISTOR	ERJ3GEYJ 103 V (10 kΩ)
R68	7030003560	S.RESISTOR	ERJ3GEYJ 103 V (10 kΩ)
R69	7030003440	S.RESISTOR	ERJ3GEYJ 102 V (1 kΩ)
R70	7030003520	S.RESISTOR	ERJ3GEYJ 472 V (4.7 kΩ)
R72	7030003640	S.RESISTOR	ERJ3GEYJ 473 V (47 kΩ)
R75	7030003350	S.RESISTOR	ERJ3GEYJ 181 V (180 Ω)
R77	7030003320	S.RESISTOR	ERJ3GEYJ 101 V (100 Ω)
R79	7030003350	S.RESISTOR	ERJ3GEYJ 181 V (180 Ω) [OTHER]
	7030003390	S.RESISTOR	ERJ3GEYJ 391 V (390 Ω) (H)
R80	7030005310	S.RESISTOR	ERJ2GEJ 124 X (120 kΩ)
R81	7030005120	S.RESISTOR	ERJ2GEJ 102 X (1 kΩ)
R82	7030003470	S.RESISTOR	ERJ3GEYJ 182 V (1.8 kΩ) (H)
	7030003510	S.RESISTOR	ERJ3GEYJ 392 V (3.9 kΩ) [OTHER]
R83	7030003380	S.RESISTOR	ERJ3GEYJ 331 V (330 Ω)
R84	7030003280	S.RESISTOR	ERJ3GEYJ 470 V (47 Ω)
R85	7030003460	S.RESISTOR	ERJ3GEYJ 152 V (1.5 kΩ)
R86	7030003630	S.RESISTOR	ERJ3GEYJ 393 V (39 kΩ) (H)
	7030003640	S.RESISTOR	ERJ3GEYJ 473 V (47 kΩ) [OTHER]
R87	7030003440	S.RESISTOR	ERJ3GEYJ 102 V (1 kΩ) (H)
	7030003480	S.RESISTOR	ERJ3GEYJ 222 V (2.2 kΩ) [OTHER]
R88	7030003610	S.RESISTOR	ERJ3GEYJ 273 V (27 kΩ) (H)
	7030003620	S.RESISTOR	ERJ3GEYJ 333 V (33 kΩ) [OTHER]
	7030003630	S.RESISTOR	ERJ3GEYJ 393 V (39 kΩ) (D)
R89	7030003450	S.RESISTOR	ERJ3GEYJ 122 V (1.2 kΩ)
R90	7030003780	S.RESISTOR	ERJ3GEYJ 684 V (680 kΩ)
R93	7030003610	S.RESISTOR	ERJ3GEYJ 273 V (27 kΩ)
R94	7030003800	S.RESISTOR	ERJ3GEYJ 105 V (1 MΩ)
R95	7030003800	S.RESISTOR	ERJ3GEYJ 105 V (1 MΩ)
R96	7030003640	S.RESISTOR	ERJ3GEYJ 473 V (47 kΩ)
R97	7030003720	S.RESISTOR	ERJ3GEYJ 224 V (220 kΩ)
R98	7030003710	S.RESISTOR	ERJ3GEYJ 184 V (180 kΩ)
R99	7030003590	S.RESISTOR	ERJ3GEYJ 183 V (18 kΩ)

[MAIN UNIT]

REF NO.	ORDER NO.		DESCRIPTION
R100	7030008060	S.RESISTOR	RR0816P-222-D (2.2 kΩ)
R101	7030003800	S.RESISTOR	ERJ3GEYJ 105 V (1 MΩ)
R102	7030003200	S.RESISTOR	ERJ3GEYJ 100 V (10 Ω)
R103	7030003570	S.RESISTOR	ERJ3GEYJ 123 V (12 kΩ)
R104	7030003680	S.RESISTOR	ERJ3GEYJ 104 V (100 kΩ)
R105	7030005000	S.RESISTOR	ERJ2GEJ 471 X (470 Ω) [OTHER]
	7030009280	S.RESISTOR	ERJ2GE (H)
R107	7030003670	S.RESISTOR	ERJ3GEYJ 823 V (82 kΩ) (I)
	7030003700	S.RESISTOR	ERJ3GEYJ 154 V (150 kΩ) [OTHER]
R108	7030003710	S.RESISTOR	ERJ3GEYJ 184 V (180 kΩ)
R109	7030005050	S.RESISTOR	ERJ2GEJ 103 X (10 kΩ)
R112	7030003800	S.RESISTOR	ERJ3GEYJ 105 V (1 MΩ)
R113	7030003660	S.RESISTOR	ERJ3GEYJ 683 V (68 kΩ)
R114	7030003600	S.RESISTOR	ERJ3GEYJ 223 V (22 kΩ) (H)
	7030003620	S.RESISTOR	ERJ3GEYJ 333 V (33 kΩ) [OTHER]
R115	7030005310	S.RESISTOR	ERJ2GEJ 124 X (120 kΩ)
R116	7030005120	S.RESISTOR	ERJ2GEJ 102 X (1 kΩ)
R117	7030003460	S.RESISTOR	ERJ3GEYJ 152 V (1.5 kΩ)
R120	7030003660	S.RESISTOR	ERJ3GEYJ 683 V (68 kΩ)
R121	7030005120	S.RESISTOR	ERJ2GEJ 102 X (1 kΩ)
R122	7030003490	S.RESISTOR	ERJ3GEYJ 272 V (2.7 kΩ) (E)
	7030009140	S.RESISTOR	ERJ2GEJ 272 X (2.7 kΩ) [OTHER]
R123	7030007300	S.RESISTOR	ERJ2GEJ 332 X (3.3 kΩ)
R125	7030003610	S.RESISTOR	ERJ3GEYJ 273 V (27 kΩ)
R126	7030003560	S.RESISTOR	ERJ3GEYJ 103 V (10 kΩ)
R127	7030003260	S.RESISTOR	ERJ3GEYJ 330 V (33 Ω)
R128	7030003200	S.RESISTOR	ERJ3GEYJ 100 V (10 Ω)
R130	7030003680	S.RESISTOR	ERJ3GEYJ 104 V (100 kΩ)
R131	7030003400	S.RESISTOR	ERJ3GEYJ 471 V (470 Ω)
R132	7030003400	S.RESISTOR	ERJ3GEYJ 471 V (470 Ω)
R133	7030004040	S.RESISTOR	ERJ3GEYJ 4R7 V (4.7 Ω)
R134	7030003480	S.RESISTOR	ERJ3GEYJ 222 V (2.2 kΩ)
R135	7030003560	S.RESISTOR	ERJ3GEYJ 103 V (10 kΩ)
R136	7030003320	S.RESISTOR	ERJ3GEYJ 101 V (100 Ω)
R137	7030003320	S.RESISTOR	ERJ3GEYJ 101 V (100 Ω)
R139	7030003520	S.RESISTOR	ERJ3GEYJ 472 V (4.7 kΩ)
R140	7030003680	S.RESISTOR	ERJ3GEYJ 104 V (100 kΩ)
R141	7030003520	S.RESISTOR	ERJ3GEYJ 472 V (4.7 kΩ)
R142	7030004980	S.RESISTOR	ERJ2GEJ 101 X (100 Ω)
R143	7210003060	VARIABLE	TP76N00N-15F-10KA-2251
R144	7030003620	S.RESISTOR	ERJ3GEYJ 333 V (33 kΩ)
R145	7030003800	S.RESISTOR	ERJ3GEYJ 105 V (1 MΩ)
R146	7030003570	S.RESISTOR	ERJ3GEYJ 123 V (12 kΩ)
R147	7030003570	S.RESISTOR	ERJ3GEYJ 123 V (12 kΩ)
R148	7030003640	S.RESISTOR	ERJ3GEYJ 473 V (47 kΩ)
R150	7030003400	S.RESISTOR	ERJ3GEYJ 471 V (470 Ω)
R152	7030005170	S.RESISTOR	ERJ2GEJ 474 X (470 kΩ)
R153	7030005170	S.RESISTOR	ERJ2GEJ 474 X (470 kΩ)
R154	7030005170	S.RESISTOR	ERJ2GEJ 474 X (470 kΩ)
R155	7030003320	S.RESISTOR	ERJ3GEYJ 101 V (100 Ω)
R159	7030003680	S.RESISTOR	ERJ3GEYJ 104 V (100 kΩ)
R160	7030003320	S.RESISTOR	ERJ3GEYJ 101 V (100 Ω)
R161	7030003440	S.RESISTOR	ERJ3GEYJ 102 V (1 kΩ)
R162	7030003440	S.RESISTOR	ERJ3GEYJ 102 V (1 kΩ)
R163	7030003560	S.RESISTOR	ERJ3GEYJ 103 V (10 kΩ)
R164	7030005310	S.RESISTOR	ERJ2GEJ 124 X (120 kΩ)
R165	7030005310	S.RESISTOR	ERJ2GEJ 124 X (120 kΩ) [F4GT] only
			[F4GS] only
R168	7030003560	S.RESISTOR	ERJ3GEYJ 103 V (10 kΩ)
R169	7030003560	S.RESISTOR	ERJ3GEYJ 103 V (10 kΩ)
R170	7030003560	S.RESISTOR	ERJ3GEYJ 103 V (10 kΩ)
R171	7030003640	S.RESISTOR	ERJ3GEYJ 473 V (47 kΩ)
R174	7030003580	S.RESISTOR	ERJ3GEYJ 153 V (15 kΩ)
R176	7030003510	S.RESISTOR	ERJ3GEYJ 392 V (3.9 kΩ)
R177	7030003440	S.RESISTOR	ERJ3GEYJ 102 V (1 kΩ)
R178	7030005340	S.RESISTOR	RR0816P-332-D (3.3 kΩ)
R181	7030005870	S.RESISTOR	RR0816R-104-D (100 kΩ)
R182	7510001280	S.THERMISTOR	NTCCM20124AG473J-T
R184	7030005050	S.RESISTOR	ERJ2GEJ 103 X (10 kΩ)
R185	7030005120	S.RESISTOR	ERJ2GEJ 102 X (1 kΩ)
R186	7030005240	S.RESISTOR	ERJ2GEJ 473 X (47 kΩ)
R190	7030003600	S.RESISTOR	ERJ3GEYJ 223 V (22 kΩ)
R191	7030003600	S.RESISTOR	ERJ3GEYJ 223 V (22 kΩ)
R192	7030003600	S.RESISTOR	ERJ3GEYJ 223 V (22 kΩ)
R193	7030003680	S.RESISTOR	ERJ3GEYJ 104 V (100 kΩ)

S.=Surface mount

- (A): L-band of ETS/CEPT version
- (B): L-band
- (C): H-band
- (D): W/N-type
- (E): M1 (440–470 MHz)-band
- (F): M1-band of [GEN] and EIA/TIA version
- (G): W-type of [GEN]
- (H): W-type
- (I): N-type
- (J): M2 (470–500 MHz)-band
- (K): M1-band of ETS/CEPT version
- (L): N-type of [GEN] and EIA/TIA version
- (M): N-type of ETS/CEPT version
- (N): M1-band except W/N-type
- (O): 100 channel version
- (P): M (20 kHz)-type

[MAIN UNIT]

REF NO.	ORDER NO.	DESCRIPTION	
R194	7030003680	S.RESISTOR	ERJ3GEYJ 104 V (100 kΩ)
R195	7030003680	S.RESISTOR	ERJ3GEYJ 104 V (100 kΩ)
R196	7030003680	S.RESISTOR	ERJ3GEYJ 104 V (100 kΩ)
R197	7030003720	S.RESISTOR	ERJ3GEYJ 224 V (220 kΩ)
R198	7030003590	S.RESISTOR	ERJ3GEYJ 183 V (18 kΩ)
R199	7030003640	S.RESISTOR	ERJ3GEYJ 473 V (47 kΩ)
R200	7030003640	S.RESISTOR	ERJ3GEYJ 473 V (47 kΩ)
R202	7030005240	S.RESISTOR	ERJ2GEJ 473 X (47 kΩ)
R203	7030003640	S.RESISTOR	ERJ3GEYJ 473 V (47 kΩ)
R204	7030003500	S.RESISTOR	ERJ3GEYJ 332 V (3.3 kΩ)
R205	7030003460	S.RESISTOR	ERJ3GEYJ 152 V (1.5 kΩ)
R207	7030005240	S.RESISTOR	ERJ2GEJ 473 X (47 kΩ)
R208	7030003680	S.RESISTOR	ERJ3GEYJ 104 V (100 kΩ)
R209	7030003680	S.RESISTOR	ERJ3GEYJ 104 V (100 kΩ)
R210	7030003480	S.RESISTOR	ERJ3GEYJ 222 V (2.2 kΩ)
R211	7030003690	S.RESISTOR	ERJ3GEYJ 124 V (120 kΩ)
R212	7030003660	S.RESISTOR	ERJ3GEYJ 683 V (68 kΩ)
R213	7030003400	S.RESISTOR	ERJ3GEYJ 471 V (470 Ω)
R215	7030005870	S.RESISTOR	RR0816R-104-D (100 kΩ)
R216	7030005870	S.RESISTOR	RR0816R-104-D (100 kΩ)
R218	7030003680	S.RESISTOR	ERJ3GEYJ 104 V (100 kΩ) ①
	7030003690	S.RESISTOR	ERJ3GEYJ 124 V (120 kΩ) [OTHER]
R219	7030003680	S.RESISTOR	ERJ3GEYJ 104 V (100 kΩ) ①
	7030003690	S.RESISTOR	ERJ3GEYJ 124 V (120 kΩ) [OTHER]
R220	7030003740	S.RESISTOR	ERJ3GEYJ 334 V (330 kΩ)
R221	7030003750	S.RESISTOR	ERJ3GEYJ 394 V (390 kΩ)
R223	7030005310	S.RESISTOR	ERJ2GEJ 124 X (120 kΩ)
R224	7030003570	S.RESISTOR	ERJ3GEYJ 123 V (12 kΩ) ④
	7030003610	S.RESISTOR	ERJ3GEYJ 273 V (27 kΩ) [OTHER]
R225	7030003680	S.RESISTOR	ERJ3GEYJ 104 V (100 kΩ)
R226	7410000950	S.ARRAY	EXB-V8V 102JV
R227	7030005240	S.RESISTOR	ERJ2GEJ 473 X (47 kΩ)
R228	7030003560	S.RESISTOR	ERJ3GEYJ 103 V (10 kΩ)
R229	7030003710	S.RESISTOR	ERJ3GEYJ 184 V (180 kΩ) [OTHER]
	7030003770	S.RESISTOR	ERJ3GEYJ 564 V (560 kΩ) ①
R230	7030003650	S.RESISTOR	ERJ3GEYJ 563 V (56 kΩ) [OTHER]
	7030003710	S.RESISTOR	ERJ3GEYJ 184 V (180 kΩ) ①
R231	7030003600	S.RESISTOR	ERJ3GEYJ 223 V (22 kΩ) [OTHER]
	7030003660	S.RESISTOR	ERJ3GEYJ 683 V (68 kΩ) ①
R232	7410000950	S.ARRAY	EXB-V8V 102JV
R234	7030003560	S.RESISTOR	ERJ3GEYJ 103 V (10 kΩ) ④
	7030003600	S.RESISTOR	ERJ3GEYJ 223 V (22 kΩ) [OTHER]
R235	7030003780	S.RESISTOR	ERJ3GEYJ 684 V (680 kΩ)
R236	7410000950	S.ARRAY	EXB-V8V 102JV
R237	7410000950	S.ARRAY	EXB-V8V 102JV
R238	7410000950	S.ARRAY	EXB-V8V 102JV
R239	7030003440	S.RESISTOR	ERJ3GEYJ 102 V (1 kΩ)
R240	7030003440	S.RESISTOR	ERJ3GEYJ 102 V (1 kΩ)
R241	7030003800	S.RESISTOR	ERJ3GEYJ 105 V (1 MΩ)
R242	7030003800	S.RESISTOR	ERJ3GEYJ 105 V (1 MΩ)
R243	7030003800	S.RESISTOR	ERJ3GEYJ 105 V (1 MΩ)
R244	7030005090	S.RESISTOR	ERJ2GEJ 104 X (100 kΩ)
R245	7030003680	S.RESISTOR	ERJ3GEYJ 104 V (100 kΩ)
R246	7030003680	S.RESISTOR	ERJ3GEYJ 104 V (100 kΩ)
R251	7030003740	S.RESISTOR	ERJ3GEYJ 334 V (330 kΩ)
R252	7030003520	S.RESISTOR	ERJ3GEYJ 472 V (4.7 kΩ)
R253	7030003400	S.RESISTOR	ERJ3GEYJ 471 V (470 Ω)
R257	7030009320	S.RESISTOR	ERJ2GEJ 4R7 X (4.7 Ω)
R258	7030003620	S.RESISTOR	ERJ3GEYJ 333 V (33 kΩ)
R260	7030003560	S.RESISTOR	ERJ3GEYJ 103 V (10 kΩ)
R261	7030003560	S.RESISTOR	ERJ3GEYJ 103 V (10 kΩ)
R262	7030003300	S.RESISTOR	ERJ3GEYJ 680 V (68 Ω) [OTHER]
	7030004050	S.RESISTOR	ERJ3GEYJ 1R0 V (1 Ω) ①
R269	7030009140	S.RESISTOR	ERJ2GEJ 272 X (2.7 kΩ) ④ only
R270	7030003640	S.RESISTOR	ERJ3GEYJ 473 V (47 kΩ) ④ only
R271	7030003640	S.RESISTOR	ERJ3GEYJ 473 V (47 kΩ) ④ only
R272	7030003680	S.RESISTOR	ERJ3GEYJ 104 V (100 kΩ) ④ only
R273	7030003680	S.RESISTOR	ERJ3GEYJ 104 V (100 kΩ) ④ only
R274	7030003560	S.RESISTOR	ERJ3GEYJ 103 V (10 kΩ) ④ only
R275	7030003520	S.RESISTOR	ERJ3GEYJ 472 V (4.7 kΩ) ④ only
R276	7030003560	S.RESISTOR	ERJ3GEYJ 103 V (10 kΩ) ④ only
R401	7030003680	S.RESISTOR	ERJ3GEYJ 104 V (100 kΩ)
R402	7030003640	S.RESISTOR	ERJ3GEYJ 473 V (47 kΩ)
R404	7030003720	S.RESISTOR	ERJ3GEYJ 224 V (220 kΩ)
R405	7030003560	S.RESISTOR	ERJ3GEYJ 103 V (10 kΩ)

[MAIN UNIT]

REF NO.	ORDER NO.	DESCRIPTION	
R410	7030003500	S.RESISTOR	ERJ3GEYJ 332 V (3.3 kΩ)
R411	7030003490	S.RESISTOR	ERJ3GEYJ 272 V (2.7 kΩ)
R413	7030003230	S.RESISTOR	ERJ3GEYJ 180 V (18 Ω) ③ only
R414	7030003380	S.RESISTOR	ERJ3GEYJ 331 V (330 Ω) [OTHER]
	7030003390	S.RESISTOR	ERJ3GEYJ 391 V (390 Ω) ④, ⑤
	7030003400	S.RESISTOR	ERJ3GEYJ 471 V (470 Ω) ④
R416	7030003500	S.RESISTOR	ERJ3GEYJ 332 V (3.3 kΩ) ④
R417	7030003500	S.RESISTOR	ERJ3GEYJ 332 V (3.3 kΩ)
R420	7030003400	S.RESISTOR	ERJ3GEYJ 471 V (470 Ω)
R421	7030005050	S.RESISTOR	ERJ2GEJ 103 X (10 kΩ)
R422	7030003720	S.RESISTOR	ERJ3GEYJ 224 V (220 kΩ)
R445	7030003360	S.RESISTOR	ERJ3GEYJ 221 V (220 Ω)
R446	7030003650	S.RESISTOR	ERJ3GEYJ 563 V (56 kΩ)
R447	7030005000	S.RESISTOR	ERJ2GEJ 471 X (470 Ω)
R448	7030003280	S.RESISTOR	ERJ3GEYJ 470 V (47 Ω)
R449	7030005000	S.RESISTOR	ERJ2GEJ 471 X (470 Ω)
R457	7030004980	S.RESISTOR	ERJ2GEJ 101 X (100 Ω)
R458	7030003440	S.RESISTOR	ERJ3GEYJ 102 V (1 kΩ)
R464	7030003410	S.RESISTOR	ERJ3GEYJ 561 V (560 Ω) ①
	7030003440	S.RESISTOR	ERJ3GEYJ 102 V (1 kΩ) [OTHER]
R465	7030003260	S.RESISTOR	ERJ3GEYJ 330 V (33 Ω)
R469	7030003490	S.RESISTOR	ERJ3GEYJ 272 V (2.7 kΩ) ① only
R473	7030004970	S.RESISTOR	ERJ2GEJ 470 X (47 Ω)
R500	7030003680	S.RESISTOR	ERJ3GEYJ 104 V (100 kΩ)
R501	7030003590	S.RESISTOR	ERJ3GEYJ 183 V (18 kΩ) ①
	7030003640	S.RESISTOR	ERJ3GEYJ 473 V (47 kΩ) [OTHER]
R502	7030005120	S.RESISTOR	ERJ2GEJ 102 X (1 kΩ)
R503	7030005050	S.RESISTOR	ERJ2GEJ 103 X (10 kΩ)
R504	7030003380	S.RESISTOR	ERJ3GEYJ 331 V (330 Ω)
R505	7030003440	S.RESISTOR	ERJ3GEYJ 102 V (1 kΩ)
R506	7030003440	S.RESISTOR	ERJ3GEYJ 102 V (1 kΩ)
R507	7030005120	S.RESISTOR	ERJ2GEJ 102 X (1 kΩ)
R508	7030005120	S.RESISTOR	ERJ2GEJ 102 X (1 kΩ)
R509	7030005050	S.RESISTOR	ERJ2GEJ 103 X (10 kΩ)
R510	7030003440	S.RESISTOR	ERJ3GEYJ 102 V (1 kΩ)
R511	7030007350	S.RESISTOR	ERJ2GEJ 393 X (39 kΩ)
R512	7030003490	S.RESISTOR	ERJ3GEYJ 272 V (2.7 kΩ)
R515	7030005310	S.RESISTOR	ERJ2GEJ 124 X (120 kΩ)
R516	7030003580	S.RESISTOR	ERJ3GEYJ 153 V (15 kΩ)
R517	7030005070	S.RESISTOR	ERJ2GEJ 683 X (68 kΩ) ①
	7030008300	S.RESISTOR	ERJ2GEJ 184 X (180 kΩ) [OTHER]
R518	7030005120	S.RESISTOR	ERJ2GEJ 102 X (1 kΩ)
R519	7030005120	S.RESISTOR	ERJ2GEJ 102 X (1 kΩ)
R520	7030007280	S.RESISTOR	ERJ2GEJ 331 X (330 Ω)
R521	7030007280	S.RESISTOR	ERJ2GEJ 331 X (330 Ω)
R522	7030003200	S.RESISTOR	ERJ3GEYJ 100 V (10 Ω)
R523	7030008410	S.RESISTOR	ERJ2GEJ 392 X (3.9 kΩ)
R524	7510001300	S.THERMISTOR	NTCCM1608 4LH 223K
R525	7030005120	S.RESISTOR	ERJ2GEJ 102 X (1 kΩ)
R526	7030005120	S.RESISTOR	ERJ2GEJ 102 X (1 kΩ)
R527	7030005120	S.RESISTOR	ERJ2GEJ 102 X (1 kΩ)
R528	7030005120	S.RESISTOR	ERJ2GEJ 102 X (1 kΩ)
R529	7030005120	S.RESISTOR	ERJ2GEJ 102 X (1 kΩ)
R530	7030004980	S.RESISTOR	ERJ2GEJ 101 X (100 Ω)
R532	7030003760	S.RESISTOR	ERJ3GEYJ 474 V (470 kΩ)
R533	7030003680	S.RESISTOR	ERJ3GEYJ 104 V (100 kΩ)
R534	7030005120	S.RESISTOR	ERJ2GEJ 102 X (1 kΩ)
C3	4030006980	S.CERAMIC	C1608 CH 1H 070D-T-A [OTHER]
	4030006990	S.CERAMIC	C1608 CH 1H 080D-T-A ②
C4	4030009520	S.CERAMIC	C1608 CH 1H 020B-T-A ④, ⑤ only
C8	4030006860	S.CERAMIC	C1608 JB 1H 102K-T-A
C9	4030006860	S.CERAMIC	C1608 JB 1H 102K-T-A
C10	4030006860	S.CERAMIC	C1608 JB 1H 102K-T-A
C11	4030011770	S.CERAMIC	C1608 CH 1H 060B-T-A
C12	4030006860	S.CERAMIC	C1608 JB 1H 102K-T-A
C13	4030006860	S.CERAMIC	C1608 JB 1H 102K-T-A
C14	4030006900	S.CERAMIC	C1608 JB 1H 103K-T-A except ④
C15	4030017500	S.CERAMIC	ECJ0EC1H560J ④, ⑤
	4030017670	S.CERAMIC	ECJ0EC1H390J [OTHER]
C17	4030006860	S.CERAMIC	C1608 JB 1H 102K-T-A
C18	4030006850	S.CERAMIC	C1608 JB 1H 471K-T-A
C19	4030006860	S.CERAMIC	C1608 JB 1H 102K-T-A
C20	4030016790	S.CERAMIC	ECJ0EB1C103K ④ only

S.=Surface mount

- ①: L-band of ETS/CEPT version
- ②: M1-band of [GEN] and EIA/TIA version
- ③: M1-band of ETS/CEPT version
- ④: M1-band except W/N-type
- ⑤: L-band
- ⑥: W-type of [GEN]
- ⑦: N-type of [GEN] and EIA/TIA version
- ⑧: 100 channel version
- ⑨: H-band
- ⑩: W-type
- ⑪: N-type of ETS/CEPT version
- ⑫: M (20 kHz)-type
- ⑬: W/N-type
- ⑭: N-type
- ⑮: M1 (440–470 MHz)-band
- ⑯: M2 (470–500 MHz)-band

[MAIN UNIT]

REF NO.	ORDER NO.	DESCRIPTION
C21	4550006540	S.TANTALUM ECST1CY475R
C22	4030007000	S.CERAMIC C1608 CH 1H 090D-T-A (C)
	4030007010	S.CERAMIC C1608 CH 1H 100D-T-A (B)
	4030007020	S.CERAMIC C1608 CH 1H 120J-T-A [OTHER]
C24	4030006850	S.CERAMIC C1608 JB 1H 471K-T-A
C25	4030009530	S.CERAMIC C1608 CH 1H 030B-T-A (E)
	4030009910	S.CERAMIC C1608 CH 1H 040B-T-A [OTHER]
C26	4030017460	S.CERAMIC ECJ0EB1E102K
C27	4030009920	S.CERAMIC C1608 CH 1H 050B-T-A
C28	4030006990	S.CERAMIC C1608 CH 1H 080D-T-A [OTHER]
	4030007020	S.CERAMIC C1608 CH 1H 120J-T-A (E)
C29	4030006850	S.CERAMIC C1608 JB 1H 471K-T-A (B, E) only
C30	4030006990	S.CERAMIC C1608 CH 1H 080D-T-A [OTHER]
	4030007020	S.CERAMIC C1608 CH 1H 120J-T-A (E)
C31	4030009520	S.CERAMIC C1608 CH 1H 020B-T-A [OTHER]
	4030009530	S.CERAMIC C1608 CH 1H 030B-T-A (E)
C32	4030006850	S.CERAMIC C1608 JB 1H 471K-T-A
C33	4030006850	S.CERAMIC C1608 JB 1H 471K-T-A
C42	4030013850	S.CERAMIC ECUE1E102KBQ
C47	4550006360	S.TANTALUM ECST1VY104R
C48	4550006450	S.TANTALUM ECST1EY105R
C50	4550006200	S.TANTALUM ECST0JY106R
C51	4030007010	S.CERAMIC C1608 CH 1H 100D-T-A
C52	4030006990	S.CERAMIC C1608 CH 1H 080D-T-A (J, C)
	4030007010	S.CERAMIC C1608 CH 1H 100D-T-A [OTHER]
	4030007030	S.CERAMIC C1608 CH 1H 150J-T-A
C54	4030013850	S.CERAMIC ECUE1E102KBQ
C55	4030016790	S.CERAMIC ECJ0EB1C103K
C56	4030016790	S.CERAMIC ECJ0EB1C103K
C60	4030013850	S.CERAMIC ECUE1E102KBQ
C61	4030011770	S.CERAMIC C1608 CH 1H 060B-T-A
C62	4030011770	S.CERAMIC C1608 CH 1H 060B-T-A
C63	4030007010	S.CERAMIC C1608 CH 1H 100D-T-A
C65	4030009910	S.CERAMIC C1608 CH 1H 040B-T-A
C66	4030006980	S.CERAMIC C1608 CH 1H 070D-T-A
C67	4030009530	S.CERAMIC C1608 CH 1H 030B-T-A
C71	4030006860	S.CERAMIC C1608 JB 1H 102K-T-A
C72	4550006320	S.TANTALUM ECST0JY475R
C73	4030011600	S.CERAMIC C1608 JB 1E 104K-T-N
C75	4030016930	S.CERAMIC ECJ0EB1A104K
C76	4030006980	S.CERAMIC C1608 CH 1H 070D-T-A (E)
	4030006990	S.CERAMIC C1608 CH 1H 080D-T-A (B)
	4030011770	S.CERAMIC C1608 CH 1H 060B-T-A [OTHER]
C78	4030009530	S.CERAMIC C1608 CH 1H 030B-T-A [OTHER]
	4030009910	S.CERAMIC C1608 CH 1H 040B-T-A (E)
	4030011770	S.CERAMIC C1608 CH 1H 060B-T-A (B)
C79	4030009520	S.CERAMIC C1608 CH 1H 020B-T-A (B)
	4030009540	S.CERAMIC C1608 CH 1H 1R5B-T-A [OTHER]
C84	4030007090	S.CERAMIC C1608 CH 1H 470J-T-A
C85	4030006980	S.CERAMIC C1608 CH 1H 070D-T-A (E)
	4030007010	S.CERAMIC C1608 CH 1H 100D-T-A (B)
	4030009920	S.CERAMIC C1608 CH 1H 050B-T-A (C)
	4030011770	S.CERAMIC C1608 CH 1H 060B-T-A (J)
C86	4030006980	S.CERAMIC C1608 CH 1H 070D-T-A (B)
	4030009350	S.CERAMIC C1608 CH 1H 3R5B-T-A (C)
	4030009910	S.CERAMIC C1608 CH 1H 040B-T-A (J)
	4030009920	S.CERAMIC C1608 CH 1H 050B-T-A (E)
C87	4030007090	S.CERAMIC C1608 CH 1H 470J-T-A
C88	4030006860	S.CERAMIC C1608 JB 1H 102K-T-A
C89	4030009500	S.CERAMIC C1608 CH 1H 0R5B-T-A
C90	4030006860	S.CERAMIC C1608 JB 1H 102K-T-A
C91	4030006970	S.CERAMIC C1608 CH 1H 060D-T-A (E)
	4030006990	S.CERAMIC C1608 CH 1H 080D-T-A (C)
	4030009920	S.CERAMIC C1608 CH 1H 050B-T-A [OTHER]
C92	4030006990	S.CERAMIC C1608 CH 1H 080D-T-A (E)
	4030007010	S.CERAMIC C1608 CH 1H 100D-T-A (B)
	4030009920	S.CERAMIC C1608 CH 1H 050B-T-A (C)
	4030011770	S.CERAMIC C1608 CH 1H 060B-T-A (J)
C93	4030014180	S.CERAMIC ECUE1H470JCCQ
C94	4030009500	S.CERAMIC C1608 CH 1H 0R5B-T-A [OTHER]
	4030009510	S.CERAMIC C1608 CH 1H 010B-T-A (B)
C95	4030014180	S.CERAMIC ECUE1H470JCCQ

[MAIN UNIT]

REF NO.	ORDER NO.	DESCRIPTION
C96	4030006990	S.CERAMIC C1608 CH 1H 080D-T-A (E)
	4030007010	S.CERAMIC C1608 CH 1H 100D-T-A (B)
	4030009920	S.CERAMIC C1608 CH 1H 050B-T-A (C)
	4030011770	S.CERAMIC C1608 CH 1H 060B-T-A (J)
C97	4030006970	S.CERAMIC C1608 CH 1H 060D-T-A (E)
	4030006990	S.CERAMIC C1608 CH 1H 080D-T-A (B)
	4030009920	S.CERAMIC C1608 CH 1H 050B-T-A [OTHER]
C98	4030007050	S.CERAMIC C1608 CH 1H 220J-T-A
C99	4030006860	S.CERAMIC C1608 JB 1H 102K-T-A
C100	4030006990	S.CERAMIC C1608 CH 1H 080D-T-A
C104	4030013850	S.CERAMIC ECUE1E102KBQ
C105	4030014180	S.CERAMIC ECUE1H470JCCQ
C106	4030007030	S.CERAMIC C1608 CH 1H 150J-T-A
C107	4030006900	S.CERAMIC C1608 JB 1H 103K-T-A
C109	4030006860	S.CERAMIC C1608 JB 1H 102K-T-A
C110	4030007020	S.CERAMIC C1608 CH 1H 120J-T-A (H, P)
	4030009990	S.CERAMIC C1608 CH 1H 200J-T-A [OTHER]
C111	4030013850	S.CERAMIC ECUE1E102KBQ
C112	4030006860	S.CERAMIC C1608 JB 1H 102K-T-A
C113	4030006860	S.CERAMIC C1608 JB 1H 102K-T-A
C114	4030006860	S.CERAMIC C1608 JB 1H 102K-T-A
C115	4030007130	S.CERAMIC C1608 CH 1H 101J-T-A
C116	4030014200	S.CERAMIC ECUE1H101JCCQ (H, P)
	4030014440	S.CERAMIC ECUE1H820JCCQ [OTHER]
C117	4030006860	S.CERAMIC C1608 JB 1H 102K-T-A
C118	4030006860	S.CERAMIC C1608 JB 1H 102K-T-A
C119	4030008680	S.CERAMIC C2012 JF 1C 105Z-T-A
C120	4030011600	S.CERAMIC C1608 JB 1E 104K-T-N
C121	4030007170	S.CERAMIC C1608 CH 1H 221J-T-A [OTHER]
	4030010760	S.CERAMIC C1608 CH 1H 331J-T-A (H, P)
C122	4030007170	S.CERAMIC C1608 CH 1H 221J-T-A [OTHER]
	4030010760	S.CERAMIC C1608 CH 1H 331J-T-A (H, P)
C123	4030013850	S.CERAMIC ECUE1E102KBQ
C124	4030006900	S.CERAMIC C1608 JB 1H 103K-T-A
C125	4030006870	S.CERAMIC C1608 JB 1H 222K-T-A
C126	4030008470	S.CERAMIC C1608 JB 1H 272K-T-A
C128	4030008680	S.CERAMIC C2012 JF 1C 105Z-T-A
C129	4550006680	S.TANTALUM ECST0JY156R
C132	4030008770	S.CERAMIC C1608 JB 1H 562K-T-A
C133	4030016930	S.CERAMIC ECJ0EB1A104K
C134	4030007160	S.CERAMIC C1608 CH 1H 181J-T-A
C135	4030007160	S.CERAMIC C1608 CH 1H 181J-T-A
C136	4030008770	S.CERAMIC C1608 JB 1H 562K-T-A
C137	4030008850	S.CERAMIC C1608 JB 1H 123K-T-A (D)
	4030008890	S.CERAMIC C1608 JB 1H 273K-T-A [OTHER]
	4030008900	S.CERAMIC C1608 JB 1H 333K-T-A (I)
C139	4030011600	S.CERAMIC C1608 JB 1E 104K-T-N
C140	4030016930	S.CERAMIC ECJ0EB1A104K
C144	4030006860	S.CERAMIC C1608 JB 1H 102K-T-A
C145	4510004630	S.ELECTROLYTIC ECEV1CA100SR
C146	4030011810	S.CERAMIC C1608 JB 1A 224K-T-N
C147	4030008630	S.CERAMIC C1608 JF 1H 104Z-T-A
C148	4030006900	S.CERAMIC C1608 JB 1H 103K-T-A
C149	4030011600	S.CERAMIC C1608 JB 1E 104K-T-N
C150	4550006200	S.TANTALUM ECST0JY106R
C151	4030014180	S.CERAMIC ECUE1H470JCCQ
C152	4030008920	S.CERAMIC C1608 JB 1H 473K-T-A
C153	4510006940	S.ELECTROLYTIC EEVFC0J101P
C154	4550006200	S.TANTALUM ECST0JY106R
C155	4510004630	S.ELECTROLYTIC ECEV1CA100SR
C156	4030006900	S.CERAMIC C1608 JB 1H 103K-T-A (D)
	4030011600	S.CERAMIC C1608 JB 1E 104K-T-N (B, E)
	4030016930	S.CERAMIC ECJ0EB1A104K (J, C)
C158	4550006620	S.TANTALUM ECST0JY226R
C159	4030006850	S.CERAMIC C1608 JB 1H 471K-T-A
C160	4030006900	S.CERAMIC C1608 JB 1H 103K-T-A
C161	4030006900	S.CERAMIC C1608 JB 1H 103K-T-A
C162	4030006900	S.CERAMIC C1608 JB 1H 103K-T-A
C163	4030013850	S.CERAMIC ECUE1E102KBQ
C164	4030006860	S.CERAMIC C1608 JB 1H 102K-T-A
C165	4030006860	S.CERAMIC C1608 JB 1H 102K-T-A
C167	4030007090	S.CERAMIC C1608 CH 1H 470J-T-A
C168	4030006860	S.CERAMIC C1608 JB 1H 102K-T-A
C169	4030006860	S.CERAMIC C1608 JB 1H 102K-T-A

S.=Surface mount

- (A): L-band of ETS/CEPT version (B): L-band (C): H-band (D): W/N-type (E): M1 (440–470 MHz)-band
 (F): M1-band of [GEN] and EIA/TIA version (G): W-type of [GEN] (H): W-type (I): N-type (J): M2 (470–500 MHz)-band
 (K): M1-band of ETS/CEPT version (L): N-type of [GEN] and EIA/TIA version (M): N-type of ETS/CEPT version
 (N): M1-band except W/N-type (O): 100 channel version (P): M (20 kHz)-type

[MAIN UNIT]

REF NO.	ORDER NO.	DESCRIPTION	
C173	4510004640	S.ELECTROLYTIC ECEV1CA470SP	[OTHER]
	4550006760	S.TANTALUM TEMSVB2 1A 336M-8R	(D)
C174	4510005430	S.ELECTROLYTIC ECEV0JA220SR	
C179	4030006900	S.CERAMIC C1608 JB 1H 103K-T-A	
C193	4030006990	S.CERAMIC C1608 CH 1H 080D-T-A	
C194	4030007020	S.CERAMIC C1608 CH 1H 120J-T-A	
C195	4030007080	S.CERAMIC C1608 CH 1H 390J-T-A	
C196	4030006850	S.CERAMIC C1608 JB 1H 471K-T-A	
C197	4030011600	S.CERAMIC C1608 JB 1E 104K-T-N	
C198	4550006170	S.TANTALUM ECST1AY225R	
C199	4030011600	S.CERAMIC C1608 JB 1E 104K-T-N	
C200	4030008900	S.CERAMIC C1608 JB 1H 333K-T-A	
C201	4030011600	S.CERAMIC C1608 JB 1E 104K-T-N	
C202	4030006900	S.CERAMIC C1608 JB 1H 103K-T-A	
C204	4030007090	S.CERAMIC C1608 CH 1H 470J-T-A	
C205	4030006860	S.CERAMIC C1608 JB 1H 102K-T-A	
C209	4030011600	S.CERAMIC C1608 JB 1E 104K-T-N	
C211	4550006320	S.TANTALUM ECST0JY475R	
C212	4030006900	S.CERAMIC C1608 JB 1H 103K-T-A	
C213	4550006170	S.TANTALUM ECST1AY225R	
C214	4030008900	S.CERAMIC C1608 JB 1H 333K-T-A	
C215	4030011600	S.CERAMIC C1608 JB 1E 104K-T-N	
C216	4030016930	S.CERAMIC ECJ0EB1A104K	
C217	4030016930	S.CERAMIC ECJ0EB1A104K	
C218	4030013850	S.CERAMIC ECUE1E102KBQ	
C219	4030009630	S.CERAMIC C1608 JB 1H 822K-T-A	
C221	4030008910	S.CERAMIC C1608 JB 1H 393K-T-A	
C222	4030011600	S.CERAMIC C1608 JB 1E 104K-T-N	
C223	4030006900	S.CERAMIC C1608 JB 1H 103K-T-A	
C224	4030006900	S.CERAMIC C1608 JB 1H 103K-T-A	
C225	4030009880	S.CERAMIC C1608 JB 1H 682K-T-A	
C227	4030008920	S.CERAMIC C1608 JB 1H 473K-T-A	(D)
	4030011600	S.CERAMIC C1608 JB 1E 104K-T-N	[OTHER]
C228	4030009490	S.CERAMIC C1608 JB 1H 821K-T-A	
C229	4030006860	S.CERAMIC C1608 JB 1H 102K-T-A	
C230	4030008880	S.CERAMIC C1608 JB 1H 223K-T-A	
C231	4030008630	S.CERAMIC C1608 JF 1H 104Z-T-A	
C232	4030008630	S.CERAMIC C1608 JF 1H 104Z-T-A	
C233	4030013850	S.CERAMIC ECUE1E102KBQ	
C234	4030013850	S.CERAMIC ECUE1E102KBQ	
C236	4030006900	S.CERAMIC C1608 JB 1H 103K-T-A	
C243	4030006860	S.CERAMIC C1608 JB 1H 102K-T-A	
C244	4030006900	S.CERAMIC C1608 JB 1H 103K-T-A	
C245	4030006900	S.CERAMIC C1608 JB 1H 103K-T-A	
C248	4030006900	S.CERAMIC C1608 JB 1H 103K-T-A	
C249	4030006900	S.CERAMIC C1608 JB 1H 103K-T-A	
C250	4030006900	S.CERAMIC C1608 JB 1H 103K-T-A	
C251	4030006860	S.CERAMIC C1608 JB 1H 102K-T-A	
C252	4030006860	S.CERAMIC C1608 JB 1H 102K-T-A	
C282	4030013850	S.CERAMIC ECUE1E102KBQ	
C283	4030013850	S.CERAMIC ECUE1E102KBQ	
C285	4030009650	S.CERAMIC C1608 CH 1H 240J-T-A	
C286	4030016920	S.CERAMIC ECUE1H222KBQ	
C288	4030006860	S.CERAMIC C1608 JB 1H 102K-T-A	
C289	4030007090	S.CERAMIC C1608 CH 1H 470J-T-A	[OTHER]
C289	4030011340	S.CERAMIC C1608 CH 1H 471J-T-A	(B)
C291	4030016930	S.CERAMIC ECJ0EB1A104K	
C307	4030013850	S.CERAMIC ECUE1E102KBQ	(D)
C308	4030006900	S.CERAMIC C1608 JB 1H 103K-T-A	(D)
C311	4030011600	S.CERAMIC C1608 JB 1E 104K-T-N	(D)
C403	4030007090	S.CERAMIC C1608 CH 1H 470J-T-A	
C404	4030006860	S.CERAMIC C1608 JB 1H 102K-T-A	
C405	4030006990	S.CERAMIC C1608 CH 1H 080D-T-A	(B)
	4030009920	S.CERAMIC C1608 CH 1H 050B-T-A	[OTHER]
	4030011770	S.CERAMIC C1608 CH 1H 060B-T-A	(E)
C406	4030006980	S.CERAMIC C1608 CH 1H 070D-T-A	(J)
	4030006990	S.CERAMIC C1608 CH 1H 080D-T-A	(E)
	4030007010	S.CERAMIC C1608 CH 1H 100D-T-A	(B)
	4030009920	S.CERAMIC C1608 CH 1H 050B-T-A	(C)
C407	4030007090	S.CERAMIC C1608 CH 1H 470J-T-A	
C410	4030006990	S.CERAMIC C1608 CH 1H 080D-T-A	(C)
	4030007010	S.CERAMIC C1608 CH 1H 100D-T-A	[OTHER]
	4030007020	S.CERAMIC C1608 CH 1H 120J-T-A	(E)

[MAIN UNIT]

REF NO.	ORDER NO.	DESCRIPTION	
C411	4030009530	S.CERAMIC C1608 CH 1H 030B-T-A	(C)
	4030009910	S.CERAMIC C1608 CH 1H 040B-T-A	(J)
	4030011770	S.CERAMIC C1608 CH 1H 060B-T-A	(E)
C412	4030011770	S.CERAMIC C1608 CH 1H 060B-T-A	
C413	4030006980	S.CERAMIC C1608 CH 1H 070D-T-A	
C414	4030006990	S.CERAMIC C1608 CH 1H 080D-T-A	[OTHER]
	4030007000	S.CERAMIC C1608 CH 1H 090D-T-A	(B)
C416	4030006860	S.CERAMIC C1608 JB 1H 102K-T-A	
C417	4030009500	S.CERAMIC C1608 CH 1H 0R5B-T-A	[OTHER]
	4030009560	S.CERAMIC C1608 CH 1H R75B-T-A	(A)
C418	4030014100	S.CERAMIC ECUE1H070CCQ	(C)
	4030014110	S.CERAMIC ECUE1H080CCQ	(J)
	4030014290	S.CERAMIC ECUE1H090CCQ	(E)
	4030014130	S.CERAMIC ECUE1H120JCCQ	(B)
C419	4030009570	S.CERAMIC C1608 CH 1H 0R3B-T-A	
C421	4030007020	S.CERAMIC C1608 CH 1H 120J-T-A	(C)
	4030009990	S.CERAMIC C1608 CH 1H 200J-T-A	[OTHER]
C422	4030006980	S.CERAMIC C1608 CH 1H 070D-T-A	
C423	4030011770	S.CERAMIC C1608 CH 1H 060B-T-A	
C424	4030007090	S.CERAMIC C1608 CH 1H 470J-T-A	
C426	4030006860	S.CERAMIC C1608 JB 1H 102K-T-A	
C427	4030009500	S.CERAMIC C1608 CH 1H 0R5B-T-A	
C443	4030016950	S.CERAMIC ECJ0EB1A473K	
C450	4030009910	S.CERAMIC C1608 CH 1H 040B-T-A	
C452	4030006990	S.CERAMIC C1608 CH 1H 080D-T-A	(C)
	4030007010	S.CERAMIC C1608 CH 1H 100D-T-A	[OTHER]
C455	4030006850	S.CERAMIC C1608 JB 1H 471K-T-A	
C467	4030006980	S.CERAMIC C1608 CH 1H 070D-T-A	[OTHER]
	4030006990	S.CERAMIC C1608 CH 1H 080D-T-A	(E)
	4030007000	S.CERAMIC C1608 CH 1H 090D-T-A	(B)
C471	4030007090	S.CERAMIC C1608 CH 1H 470J-T-A	
C472	4030014180	S.CERAMIC ECUE1H470JCCQ	
C473	4030007090	S.CERAMIC C1608 CH 1H 470J-T-A	
C475	4030014420	S.CERAMIC ECUE1H0R5BCQ	(C)
	4030014000	S.CERAMIC ECUE1H1R5BCQ	(E)
	4030014070	S.CERAMIC ECUE1H040BCQ	(B)
C486	4030006980	S.CERAMIC C1608 CH 1H 070D-T-A	(B)
	4030009920	S.CERAMIC C1608 CH 1H 050B-T-A	[OTHER]
C491	4550006450	S.TANTALUM ECST1EY105R	
C492	4030007010	S.CERAMIC C1608 CH 1H 100D-T-A	
C495	4030016930	S.CERAMIC ECJ0EB1A104K	
C496	4030006880	S.CERAMIC C1608 JB 1H 472K-T-A	
C501	4550006200	S.TANTALUM ECST0JY106R	
C550	4550006620	S.TANTALUM ECST0JY226R	
C551	4030006860	S.CERAMIC C1608 JB 1H 102K-T-A	
C552	4030006860	S.CERAMIC C1608 JB 1H 102K-T-A	
C553	4030014180	S.CERAMIC ECUE1H470JCCQ	
C554	4030006850	S.CERAMIC C1608 JB 1H 471K-T-A	
C555	4030009530	S.CERAMIC C1608 CH 1H 030B-T-A	(A)
	4030009920	S.CERAMIC C1608 CH 1H 050B-T-A	[OTHER]
	4030011770	S.CERAMIC C1608 CH 1H 060B-T-A	(C)
C556	4030014180	S.CERAMIC ECUE1H470JCCQ	
C557	4030007090	S.CERAMIC C1608 CH 1H 470J-T-A	
C558	4030014180	S.CERAMIC ECUE1H470JCCQ	
C559	4030007090	S.CERAMIC C1608 CH 1H 470J-T-A	
C560	4030007090	S.CERAMIC C1608 CH 1H 470J-T-A	
C561	4030014180	S.CERAMIC ECUE1H470JCCQ	
C562	4030007090	S.CERAMIC C1608 CH 1H 470J-T-A	
C563	4030007090	S.CERAMIC C1608 CH 1H 470J-T-A	
C564	4030007090	S.CERAMIC C1608 CH 1H 470J-T-A	
C565	4030014180	S.CERAMIC ECUE1H470JCCQ	
C566	4030007090	S.CERAMIC C1608 CH 1H 470J-T-A	
C567	4030007090	S.CERAMIC C1608 CH 1H 470J-T-A	
C571	4030014180	S.CERAMIC ECUE1H470JCCQ	
C572	4030014180	S.CERAMIC ECUE1H470JCCQ	
C573	4030014180	S.CERAMIC ECUE1H470JCCQ	
C574	4030006860	S.CERAMIC C1608 JB 1H 102K-T-A	
C575	4030014180	S.CERAMIC ECUE1H470JCCQ	(C) only
C659	4030006860	S.CERAMIC C1608 JB 1H 102K-T-A	
C662	4030016930	S.CERAMIC ECJ0EB1A104K	
C663	4030008920	S.CERAMIC C1608 JB 1H 473K-T-A	
C664	4030013850	S.CERAMIC ECUE1E102KBQ	
C665	4030014180	S.CERAMIC ECUE1H470JCCQ	

S.=Surface mount

- (A): L-band of ETS/CEPT version (B): L-band (C): H-band (D): W/N-type (E): M1 (440-470 MHz)-band
 (F): M1-band of [GEN] and EIA/TIA version (G): W-type of [GEN] (H): W-type (I): N-type (J): M2 (470-500 MHz)-band
 (K): M1-band of ETS/CEPT version (L): N-type of [GEN] and EIA/TIA version (M): N-type of ETS/CEPT version
 (N): M1-band except W/N-type (O): 100 channel version (P): M (20 kHz)-type

[MAIN UNIT]

REF NO.	ORDER NO.	DESCRIPTION	
C666	4030009910	S.CERAMIC	C1608 CH 1H 040B-T-A [OTHER]
	4030009920	S.CERAMIC	C1608 CH 1H 050B-T-A (J)
C668	4030009530	S.CERAMIC	C1608 CH 1H 030B-T-A (H), (P)
C669	4030014180	S.CERAMIC	ECUE1H470JCQ
C670	4030006850	S.CERAMIC	C1608 JB 1H 471K-T-A except (B)
	4030017730	S.CERAMIC	ECJ0EB1E471K (A)
C672	4030014180	S.CERAMIC	ECUE1H470JCQ
C673	4030014180	S.CERAMIC	ECUE1H470JCQ
C674	4030014180	S.CERAMIC	ECUE1H470JCQ
C675	4030014220	S.CERAMIC	ECUE1E471KBQ
C677	4030014220	S.CERAMIC	ECUE1E471KBQ
C678	4030013850	S.CERAMIC	ECJ0EB1E102K (B)
C678	4030017730	S.CERAMIC	ECJ0EB1E471K (J)
C679	4030017420	S.CERAMIC	ECJ0EC1H470J (D)
J2	6450001680	CONNECTOR	HSJ1122-010010
J3	6450001690	CONNECTOR	HSJ1456-01-220
J5	6510018430	S.CONNECTOR	AXN330C038P
J6	6510021900	S.CONNECTOR	BM02B-ASRS-TF
DS1	5030001800	LCD	LM-7045B
DS2	5010000160	S.LED	LNJ310M6URA
DS3	5010000160	S.LED	LNJ310M6URA
MC1	7700002160	MICROPHON	KUC3523-040245
S1	2230001070	S.SWITCH	JPM1990-2711R
S2	2230001070	S.SWITCH	JPM1990-2711R
S3	2230001070	S.SWITCH	JPM1990-2711R
SP1	2510001060	SPEAKER	K036NA500-47
W1	8900009640	CABLE	OPC-963
W5	7030009970	S.JUMPER	MJ-0.1
W10	7030003860	S.JUMPER	ERJ3GE JPW V
W11	7030003860	S.JUMPER	ERJ3GE JPW V
W12	7030003860	S.JUMPER	ERJ3GE JPW V
W15	7030010040	S.JUMPER	ERJ2GE-JPW
W16	7030003860	S.JUMPER	ERJ3GE JPW V except (C)
EP1	0910052735	PCB	B 5387E (N)
	0910053271	PCB	B 5541A (B)
	0910053762	PCB	B 5542B (J), (C)
	0910054202	PCB	B 5688B (D)
EP2	8930051310	LCD CONTACT	SRCN-2251-SP-N-W
EP10	6910013370	S.BEAD	BLM11B221SB
EP11	6910013370	S.BEAD	BLM11B221SB
EP12	6910013370	S.BEAD	BLM11B221SB
EP13	6910013370	S.BEAD	BLM11B221SB
EP14	6910013370	S.BEAD	BLM11B221SB
EP15	6910013370	S.BEAD	BLM11B221SB (E), (J) only

S.=Surface mount

- | | | | | |
|---|--|---------------------------------|----------------------|----------------------------|
| (A): L-band of ETS/CEPT version | (B): L-band | (C): H-band | (D): W/N-type | (E): M1 (440–470 MHz)-band |
| (F): M1-band of [GEN] and EIA/TIA version | (G): W-type of [GEN] | (H): W-type | (I): N-type | (J): M2 (470–500 MHz)-band |
| (K): M1-band of ETS/CEPT version | (L): N-type of [GEN] and EIA/TIA version | (M): N-type of ETS/CEPT version | | |
| (N): M1-band except W/N-type | (O): 100 channel version | | (P): M (20 kHz)-type | |

SECTION 7 MECHANICAL PARTS AND DISASSEMBLY

[CHASSIS PARTS]

REF. NO.	ODER NO.	DESCRIPTION	QTY.
MP1	8210016541	2251 T-front panel-1 [F4GT]	1
	8210016671	2251 S-front panel-1 [F4GS]	1
MP2	8930050890	2251 terminal holder	1
MP3	8010017991	2251 chassis-1	1
MP4	8210016570	2251 rear panel	1
MP5	8930050870	2251 release button	1
MP6	8210016560	2251 PTT panel	1
MP7	8310047580	2251 window plate	1
MP8	8930051350	2251 jack rubber	1
MP9	8210016550	2251 jack panel	1
MP10	8610010780	Knob N-276	1
MP12	8930050820	2251 main seal	1
MP13	8930050790	2251 10-key [F4GT]	1
	8930050590	2251 6-key [F4GS]	1
MP14	8930050840	2251 minus terminal	1
MP15	8930050850	2251 plus terminal	1
MP17	8930050860	2251 PTT button	1
MP18	8930050880	2251 spring holder	1
MP20	8930042350	1922 mic sheet	1
MP21	8930051300	2251 mic sponge	1
MP22	8930051290	2251 opt sheet	1
MP23	8830001340	1903 hex nut	1
MP24	8930050900	2251 window sheet	1
MP25	8930036751	Spring	1
MP26	8950005260	Ant connector-102	1
MP27	8830001250	Ant connector-101	1
MP29	8930040390	SP net (B)	1
MP31	8810009510	Screw BT M2 x 4 NI-ZU	8
MP32	8810009560	Screw BT M2 x 6 ZK	7
MP33	8810000100	Screw M2 x 4	4
MP36	8930051330	2251 contact rubber	1
MP37	8930050800	2251 jack cap	1
MP38	8950005240	2251 contact spring	1
MP39	8860001210	2251 ANT rug	1
MP41	8510013022	2252 shield plate-2	1
MP42	8930053110	Aluminum sheet (AE)	1
MP43	8510013210	2252 jack shield	1

[ACCESSORIES]

REF. NO.	ODER NO.	DESCRIPTION	QTY.
EP1	Optional product	Antenna FA-SC25U (Blue) (A)	1
	Optional product	Antenna FA-SC57U (Red) (B)	1
	Optional product	Antenna FA-SC72U (Green) (C)	1
EP2	Optional product	Battery BP-209 Exp-recycle ACC [other]	1
	Optional product	Battery BP-209 RBRC-recycle ACC [EIA/TIA]	1
MP1	8930042041	1922 Belt clip-1	1
MP2	8930051290	2251 OPT sheet	1

(A): L-band

(B): 440–470 MHz band

(C): 470–500 MHz and H-band

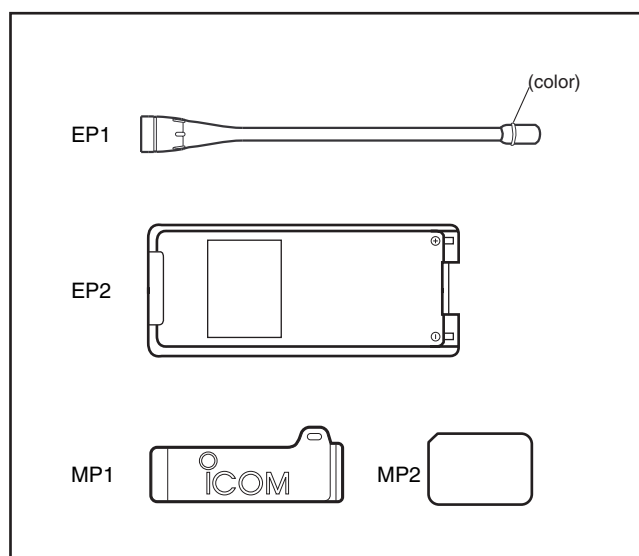

[MAIN UNIT]

REF. NO.	ODER NO.	DESCRIPTION	QTY.
DS1	5030001800	LM-7045B	1
SP1	2510001060	Speaker K036NA500-47	1
EP2	8930051310	LCD contact SRCN-2251-SP-N-W	1
MP1	8510011111	1922 VCO case-1	1
MP3	8930050811	2251 LCD holder-1	1
MP4	8210016580	2251 reflector	1
MP5	8410002230	2078 PA heatsink	1
MP6	8510011180	1923 VCO cover	1
MP8	8930052270	Shield sponge (d)	1
MP9	8930053200	2252 CPU plate [ETS/CEPT]	1

Screw abbreviations BT: Self-tapping
 NI-ZU: Nickel-zinc
 ZK: Black

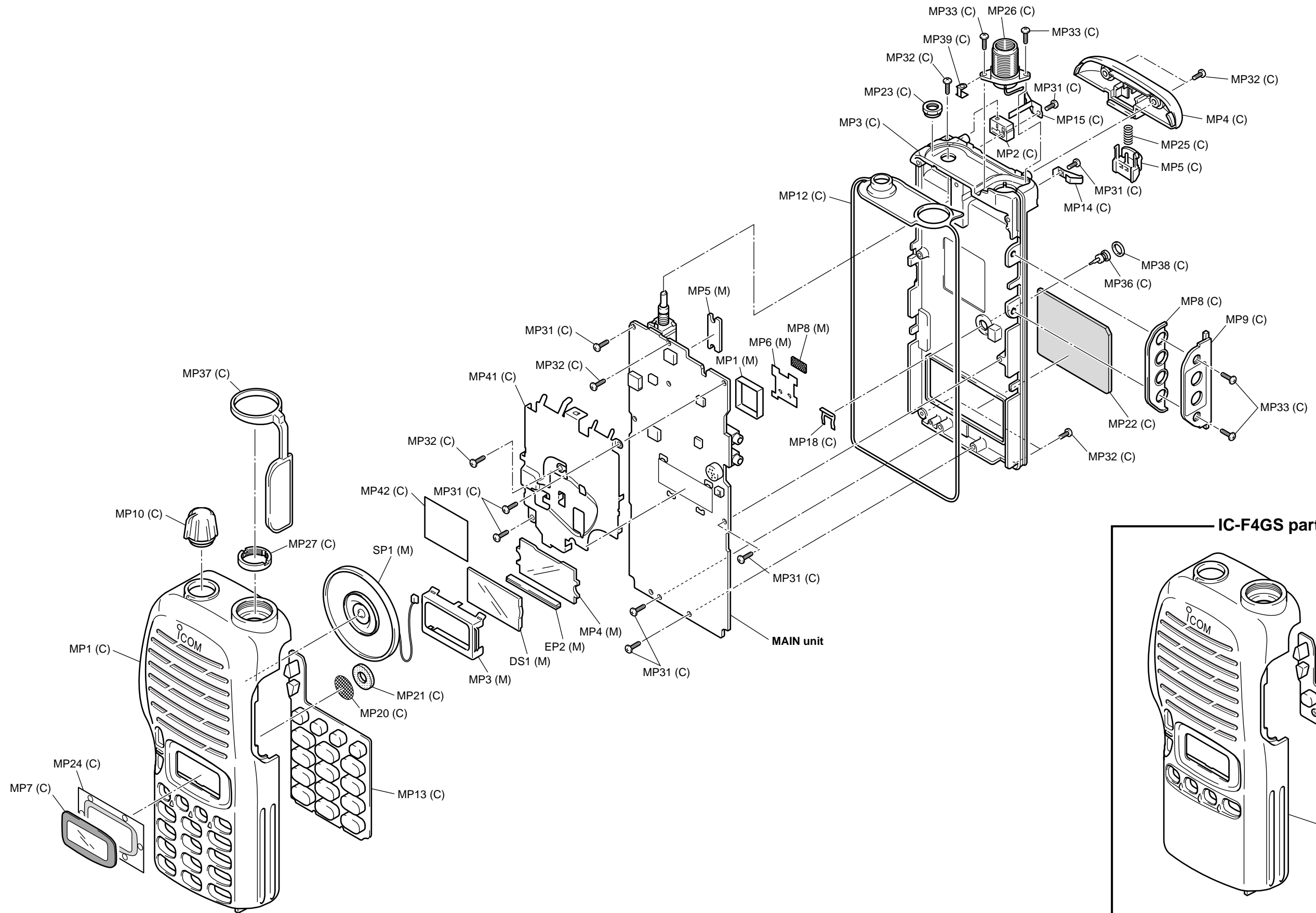



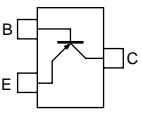
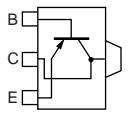
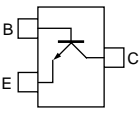
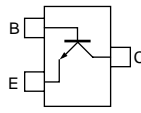
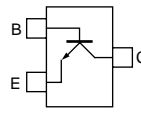
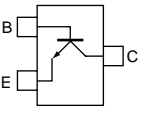
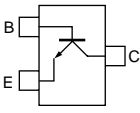
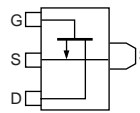
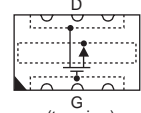
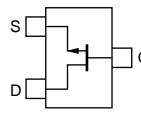
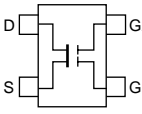
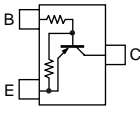
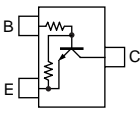
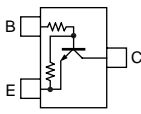
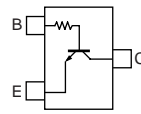
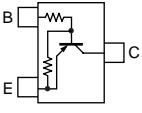
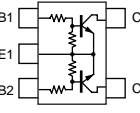
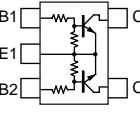
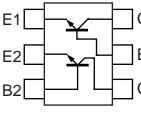

UNIT abbreviation (C): CHASSIS PARTS, (M): MAIN UNIT

SECTION 8 SEMI-CONDUCTOR INFORMATION

• TRANSISTOR AND FET'S

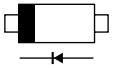
2SA1577 Q (Symbol: HQ) 	2SB1132 R (Symbol: BARB) 	2SC3585 R44 (Symbol: R44) 	2SC4116 GR (Symbol: LG) 	2SC4215 O (Symbol: QO) 
2SC5085 Y (Symbol: MCY) 	2SC5107 O (Symbol: MFO) 	2SK2973 (Symbol: K1) 	2SK2974 (Symbol: K2974)  <small>(top view)</small>	2SK880 Y (Symbol: XY) 
3SK239 A (Symbol: XR) 	DTA144 EU (Symbol: 16) 	DTC144 EE (Symbol: 26) 	DTC144 EU (Symbol: 26) 	DTC144 TU (Symbol: 06) 
UN911 H (Symbol: 6P) 	XP1213 (Symbol: 9L) 	XP1214 (Symbol: 9H) 	XP6501 AB (Symbol: 5N) 	

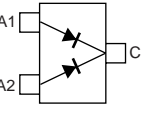
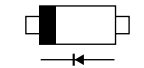
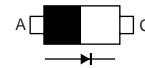
• DIODES

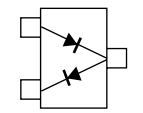
1SV245 (Symbol: T3) 	1SV307 (Symbol: TX) 	DAN202K (Symbol: N) 	HVU350B (Symbol: BO) 	MA77 (Symbol: 4B) 
MA8030 H (Symbol: 3^0) 	RB706F-40 (Symbol: 3J) 			

SECTION 9 BOARD LAYOUTS

9-1 LOW BAND • MAIN UNIT (TOP VIEW)

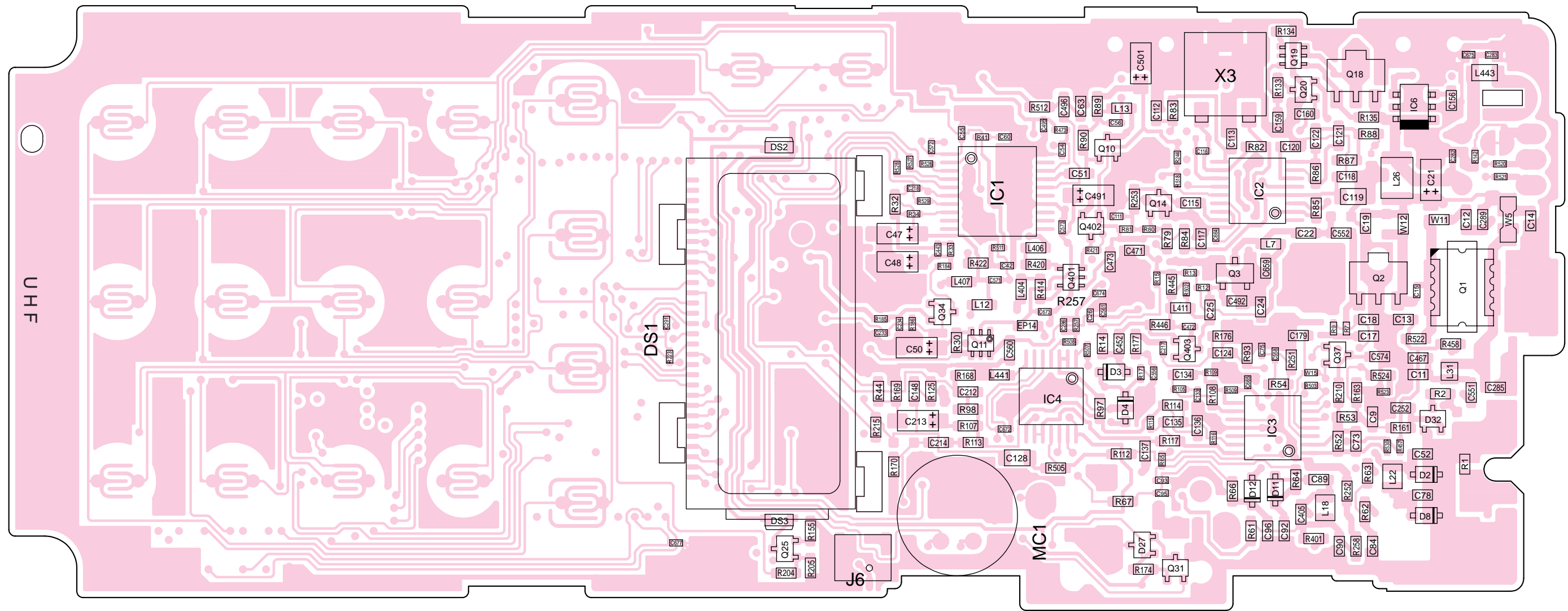

• MAIN UNIT (BOTTOM VIEW)

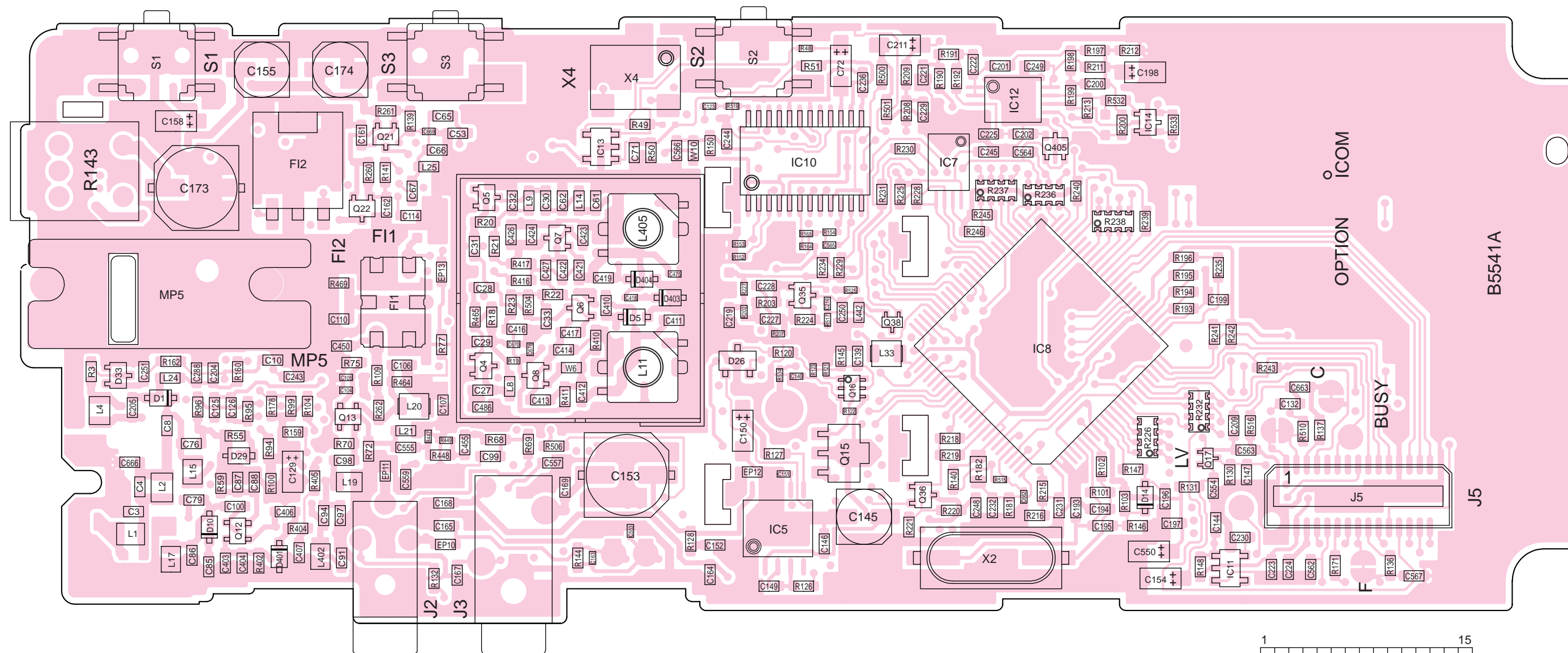

1	PTTIN	15
	PITOUT	
	MICOUT	
	MICMUTE	
	AFONOP	
	AUX	
	BEEPOUT	
	BUSY	
	RXMUTE	
	MOWN	
	SIGOUT	
	OPT1	
	OPT2	
	OPT3	
	CCS	
	CIRQ	
	GND	
	SI	
	OPV3	
	OPV1	16
30		

J5
to the OPTIONAL unit

9-2 440-470 MHz BAND EXCEPT W/N-TYPE
• MAIN UNIT (TOP VIEW)

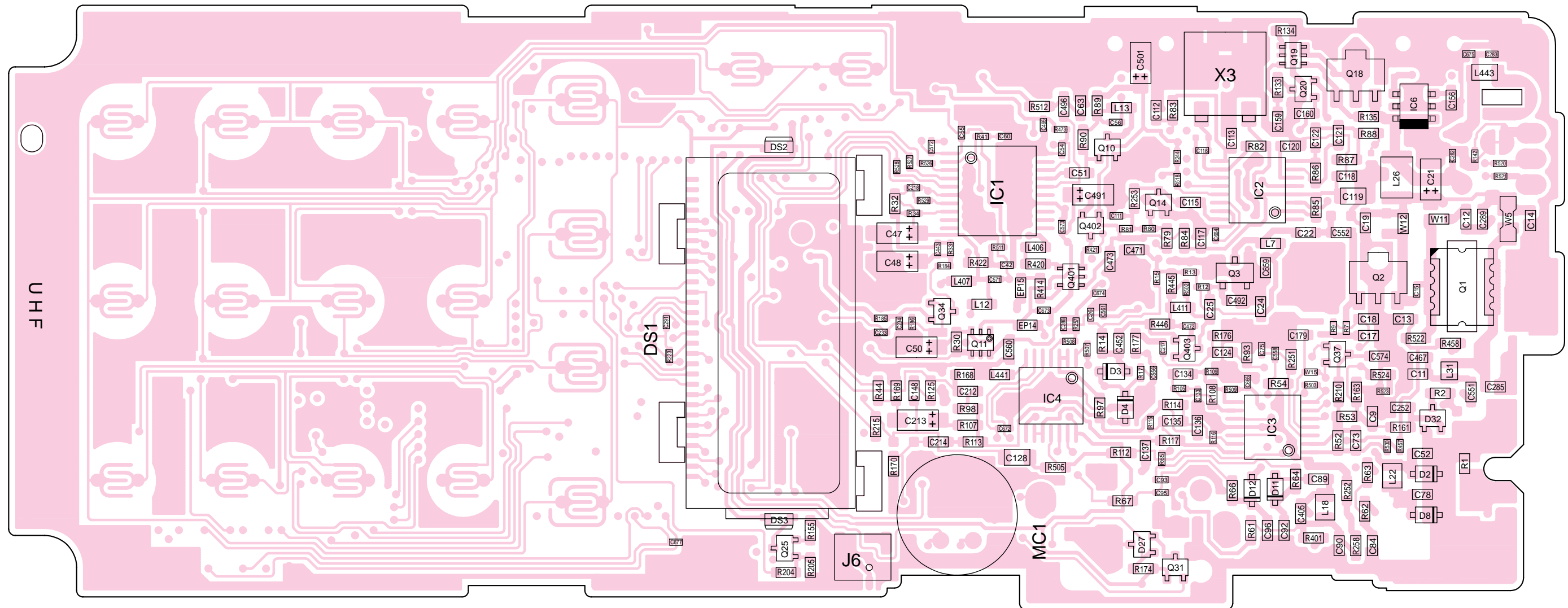

• MAIN UNIT (BOTTOM VIEW)

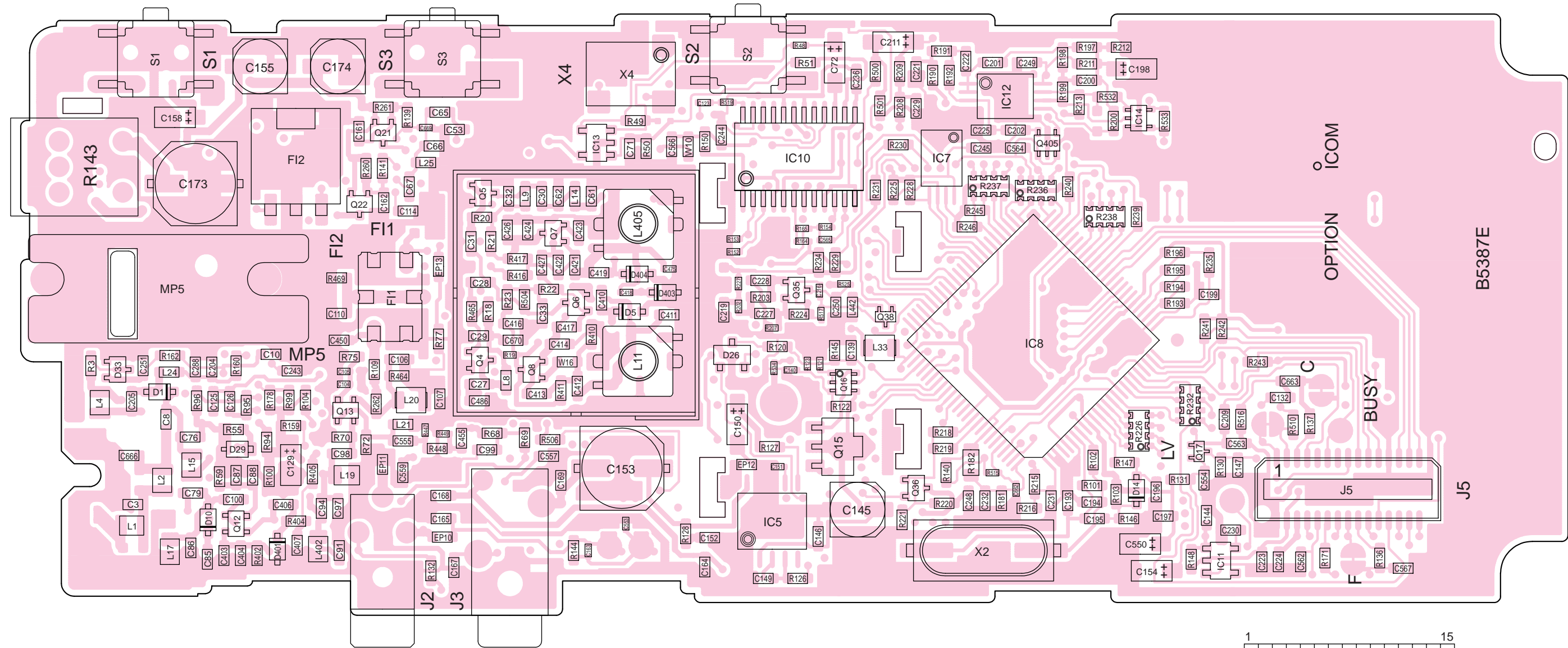

1	PTTIN	15
2	PTTOUT	
3	MICOUT	
4	MICMUTE	
5	AFONOP	
6	BEEPOUT	
7	BUSY	
8	RXMUTE	
9	MOWN	
10	DISCIN	
11	SIGOUT	
12	OPT1	
13	REM	
14	OPT2	
15	OPT3	
16	CCS	
17	CIRQ	
18	GND	
19	SO	
20	SI	
21	OPV3	
22	OPV2	
23	OPV1	
30		

J5
to the OPTIONAL unit

9-3 470-500 MHz AND HIGH BANDS
• MAIN UNIT (TOP VIEW)

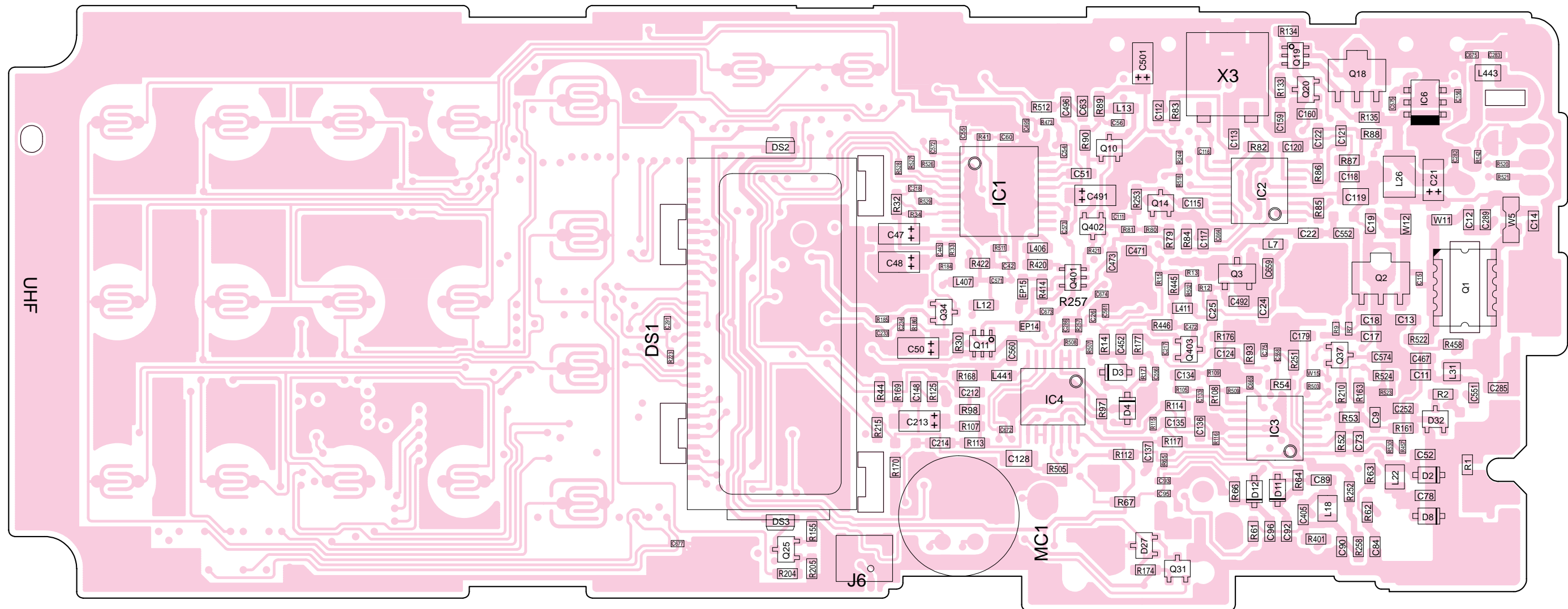

• MAIN UNIT (BOTTOM VIEW)

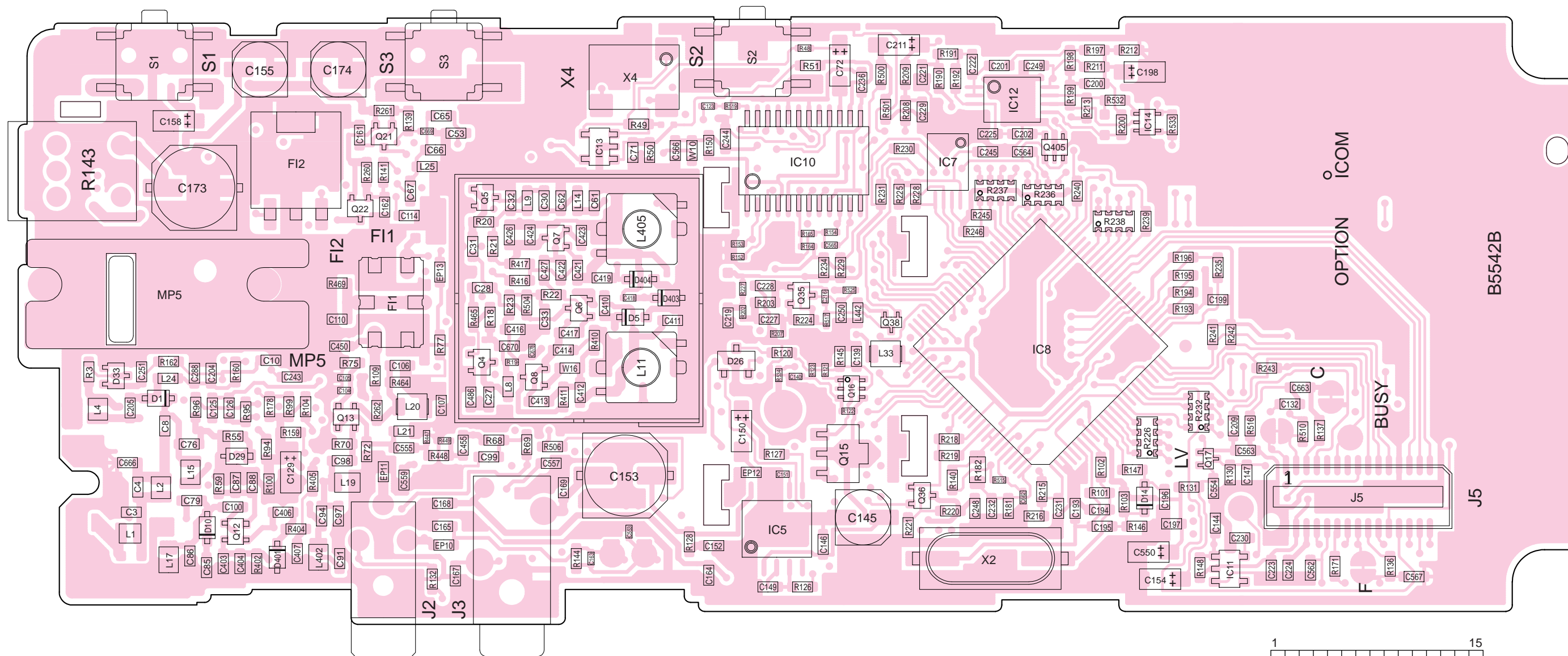

1	P11IN	15
	P11OUT	
	MICOUT	
	MICMUTE	
	AFONOP	
	BEEPOUT	
	RXMUTE	
	DISCIN	
	AFOUT	
	REM	
	CCS	
	CIRQ	
	SO	
	SCK	
30		16

J5
to the OPTIONAL unit

9-4 W/N-TYPE
• MAIN UNIT (TOP VIEW)

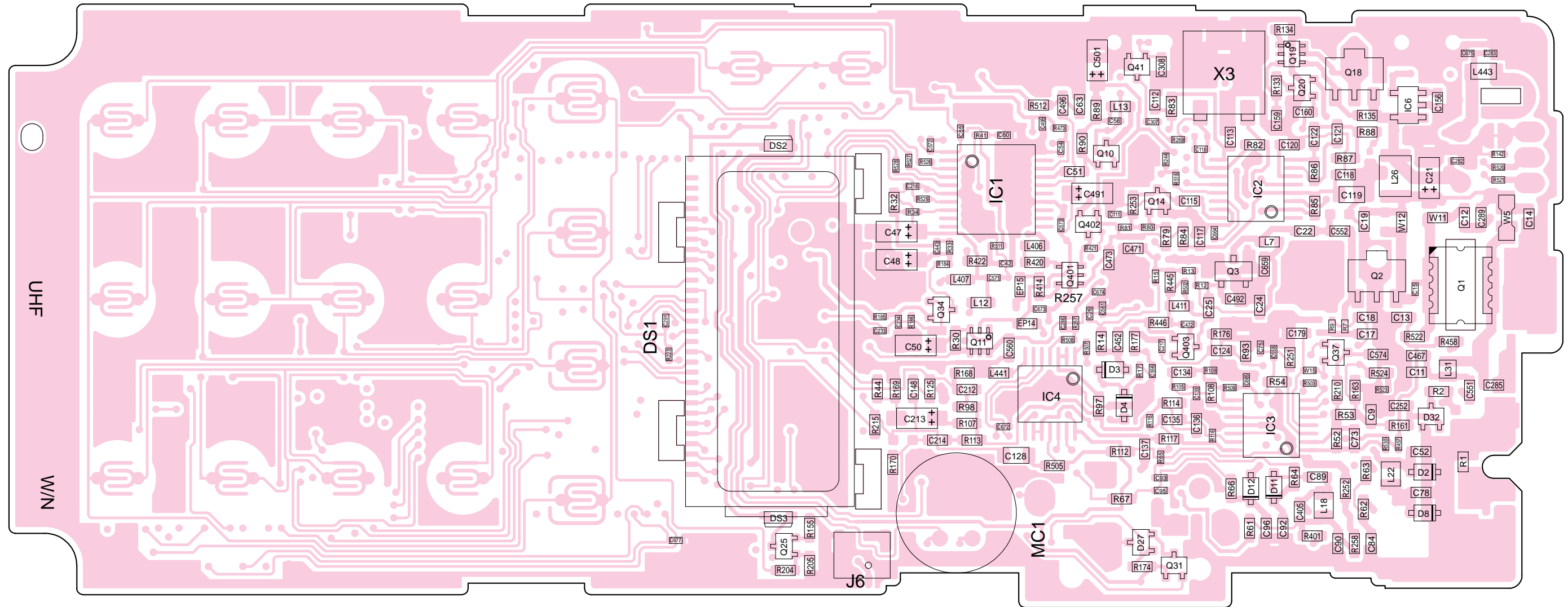

• MAIN UNIT (BOTTOM VIEW)

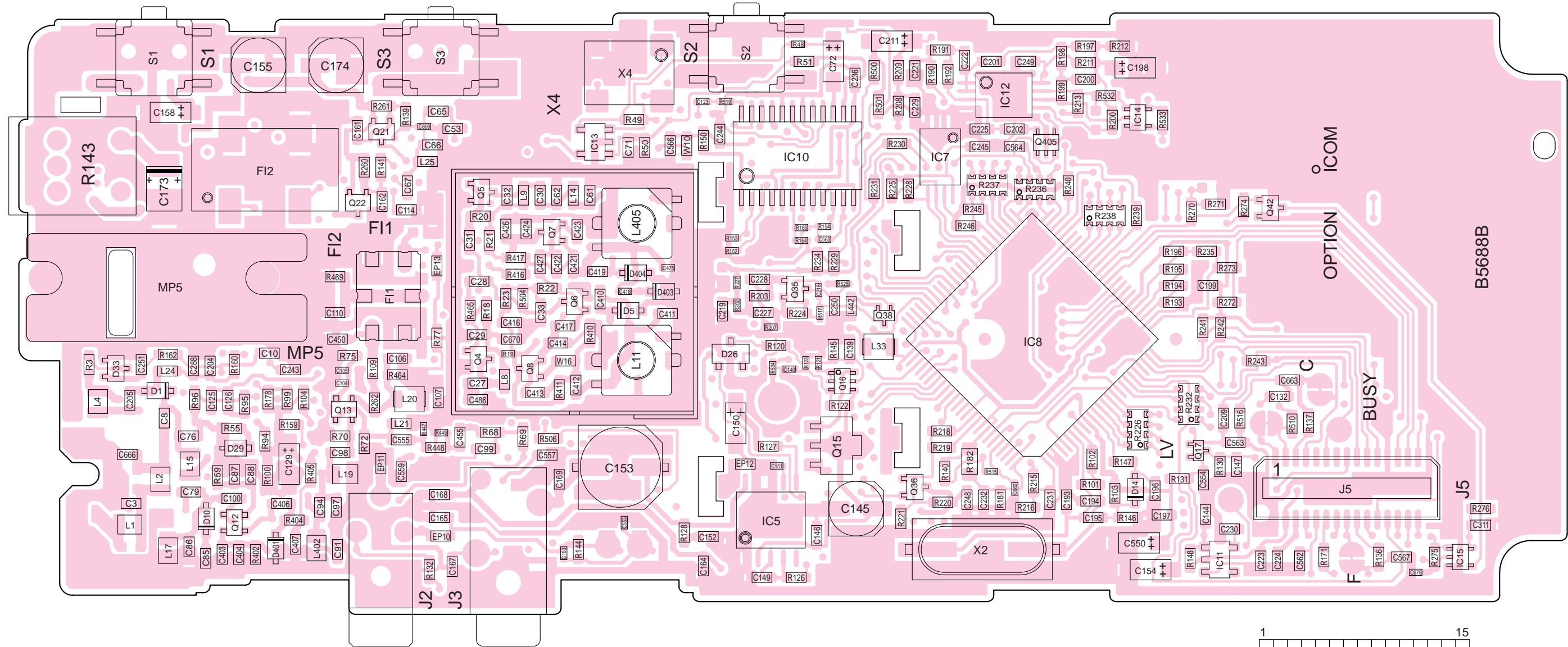

1	PTTIN	15
	PTTOUT	
	MICOUT	
	MICMUTE	
	AFONOP	
	BEEPOUT	
	RXMUTE	
	DISCIN	
	AFOUT	
	REM	
	CCS	
	CIRQ	
	SO	
	SI	
	SCK	
30		16

J5
to the OPTIONAL unit

SECTION 10 BC-137 OPTIONAL DESKTOP CHARGER INFORMASION

10-1 PARTS LIST

[MAIN UNIT]

REF. NO.	ODER NO.	DESCRIPTION	QTY.
Q1	1520000650	S.TRANSISTOR 2SB1201-S-TL	1
Q2	1590000480	S.TRANSISTOR RN2402 (TE85R)	1
Q3	1590000510	S.TRANSISTOR RN1409 (TE85R)	1
Q4	1530001950	S.TRANSISTOR 2SC2712-GR (TE85R)	1
D1	1750000550	S.DIODE 1SS355 TE-17	1
D2	1750000020	S.DIODE 1SS184 (TE85R)	1
D3	1790000950	S.ZENER MA8056-M (TX)	1
R1	7030010000	S.RESISTOR MCR10EZHF 24R0 Ω (240)	1
R2	7030010000	S.RESISTOR MCR10EZHF 24R0 Ω (240)	1
R3	7030000190	S.RESISTOR MCR10EZHJ 27 Ω (270)	1
R4	7030000500	S.RESISTOR MCR10EZHJ 10 kΩ	1
R5	7030000500	S.RESISTOR MCR10EZHJ 10 kΩ	1
R6	7030000190	S.RESISTOR MCR10EZHJ 27 Ω (270)	1
R7	7030001740	S.RESISTOR MCR10EZHJ 2 kΩ	1
R8	7030001740	S.RESISTOR MCR10EZHJ 2 kΩ	1
R9	7030000590	S.RESISTOR MCR10EZHJ 56 kΩ	1
R10	7030000500	S.RESISTOR MCR10EZHJ 10 kΩ	1
R11	7030000380	S.RESISTOR MCR10EZHJ 1 kΩ	1
C1	4030001150	S.CERAMIC GRM40 F 104Z 25PT	1
C2	4030001150	S.CERAMIC GRM40 F 104Z 25PT	1
C3	4030001150	S.CERAMIC GRM40 F 104Z 25PT	1
C4	4030001150	S.CERAMIC GRM40 F 104Z 25PT	1
J1	6510021470	CONNECTOR HEC0470-01-230	1
J2	6510021470	CONNECTOR HEC0470-01-230	1
DS1	5040001390	LED TLG124A	1
W1	7030003970	S.JUMPER MCR18EZHJ JPW (000)	1
EP1	0910052602	PCB B 5493B	1
EP2	6910012240	SPACER TLE60-05	1
MP1	8930051340	2338 TERMINAL	3

S.=Surface mount

10-2 DISASSEMBLY INFORMATION

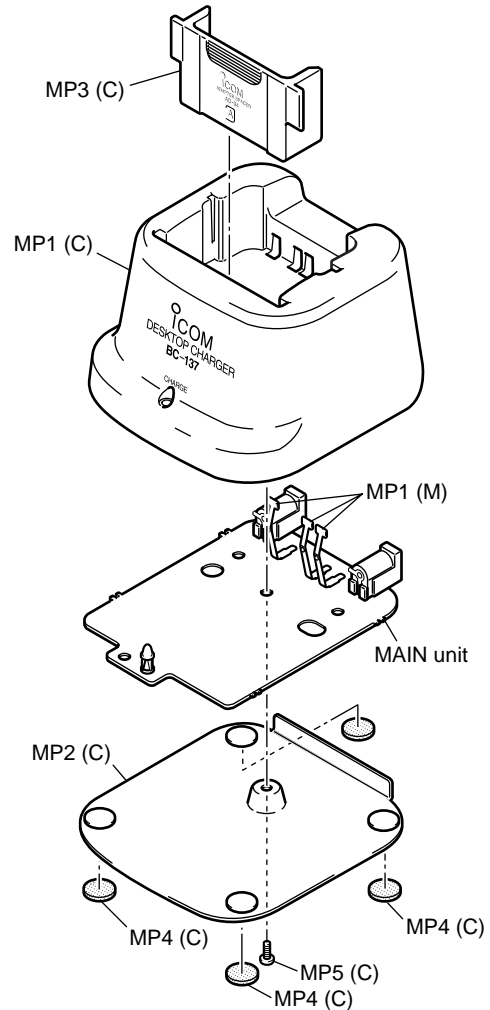

NOTE: (C) : CHASSIS
(M) : MAIN UNIT

[CHASSIS UNIT]

REF. NO.	ODER NO.	DESCRIPTION	QTY.
MP1	8010018030	2338 case	1
MP2	8110007080	2338 cover	1
MP3	8930050920	2327 spacer	1
MP4	8930039620	Leg cushion (A)	4
MP5	8810008660	Screw BT M3 x 8 NI-ZU	1

Screw abbreviations BT : Self-tapping
NI : Nickel

CONVENIENT:

BC-137 is connectable max. 6 pieces in parallel.
When connect BC-137 in parallel, JIG cable (as shown below) is required.

• CONNECTION

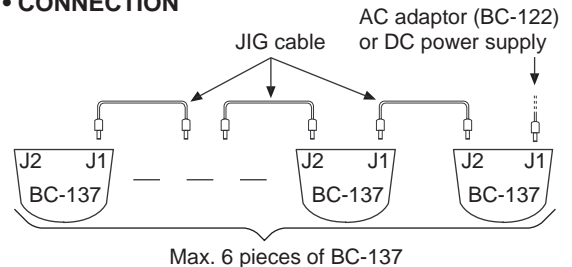

• JIG CABLE

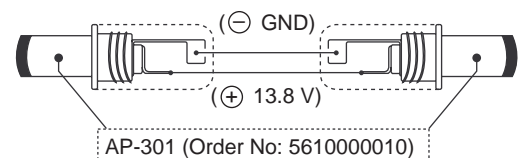

10-3 VOLTAGE DIAGRAM

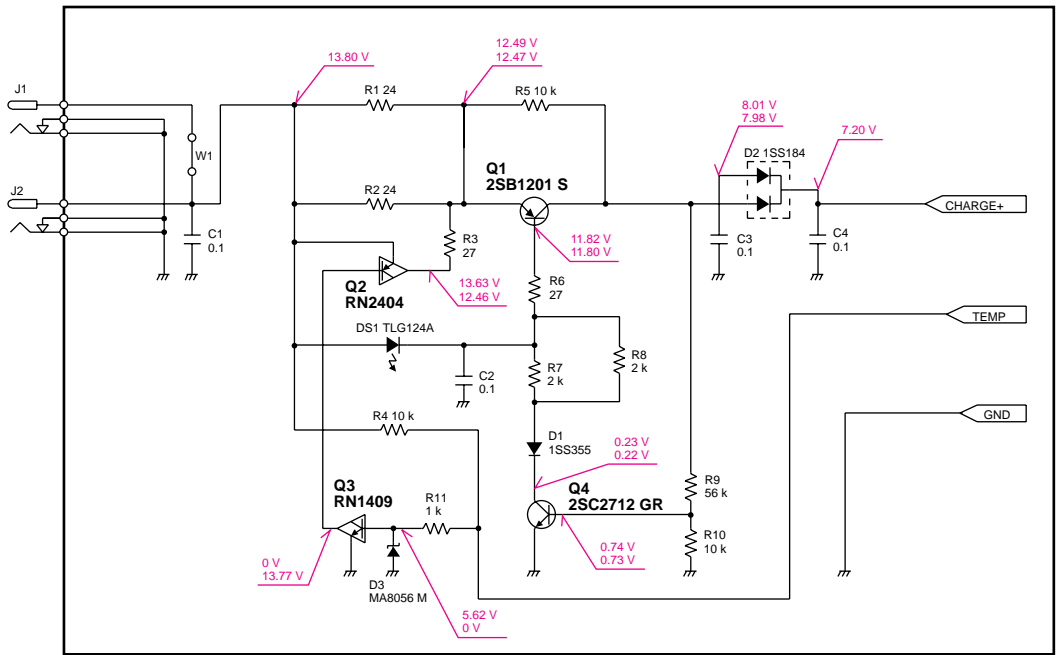

10-4 BOARD LAYOUT

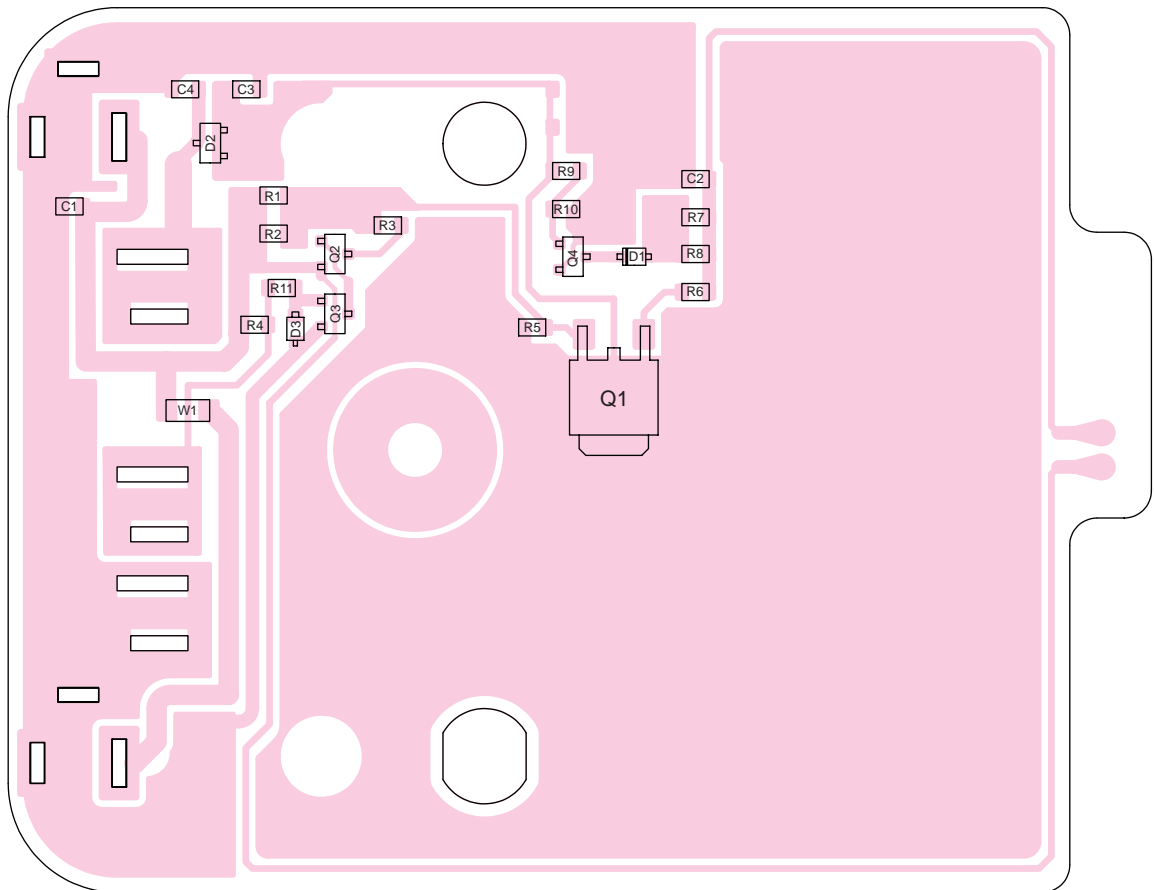

SECTION 11 BLOCK DIAGRAM

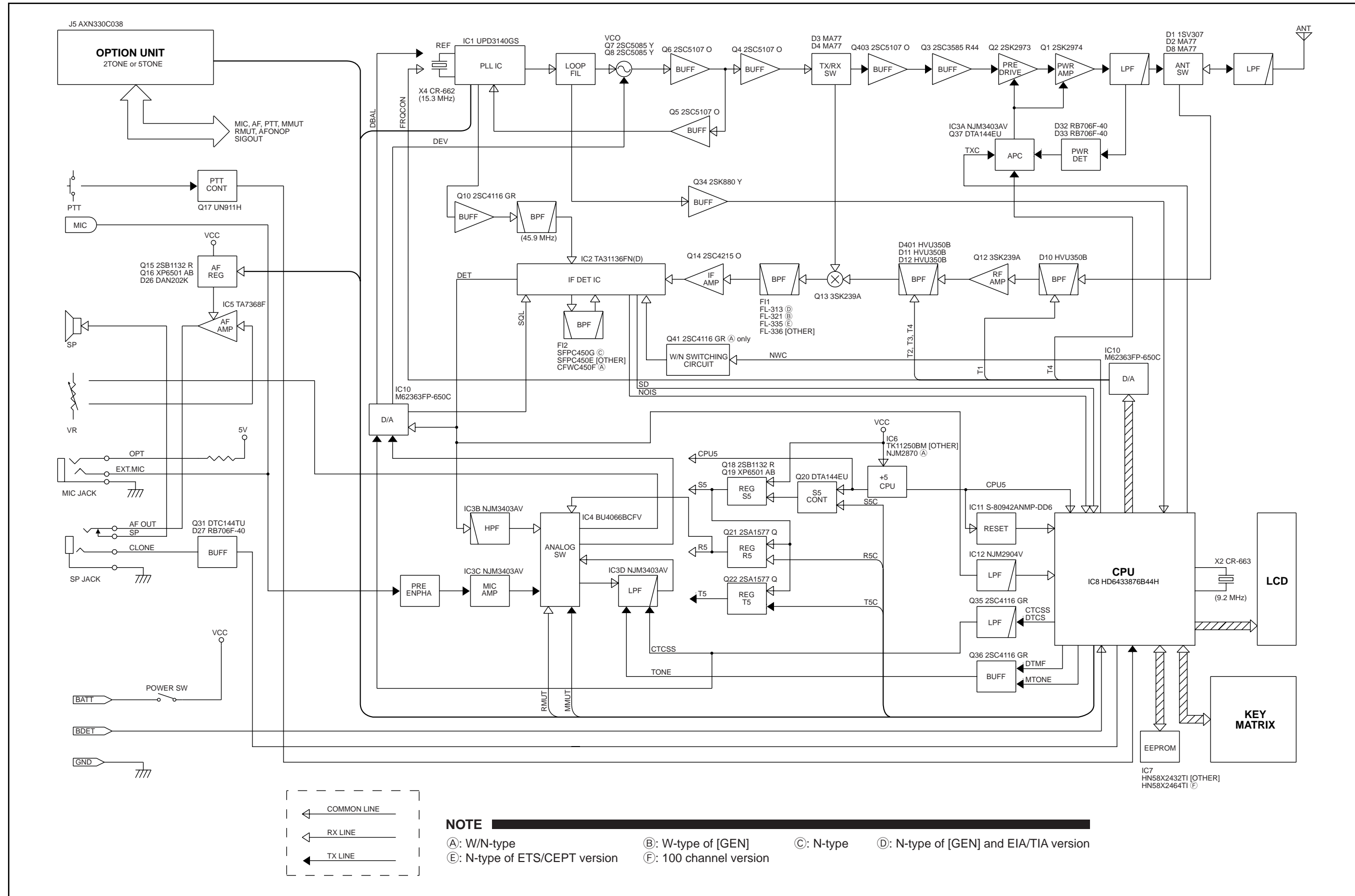

SECTION 12 VOLTAGE DIAGRAM

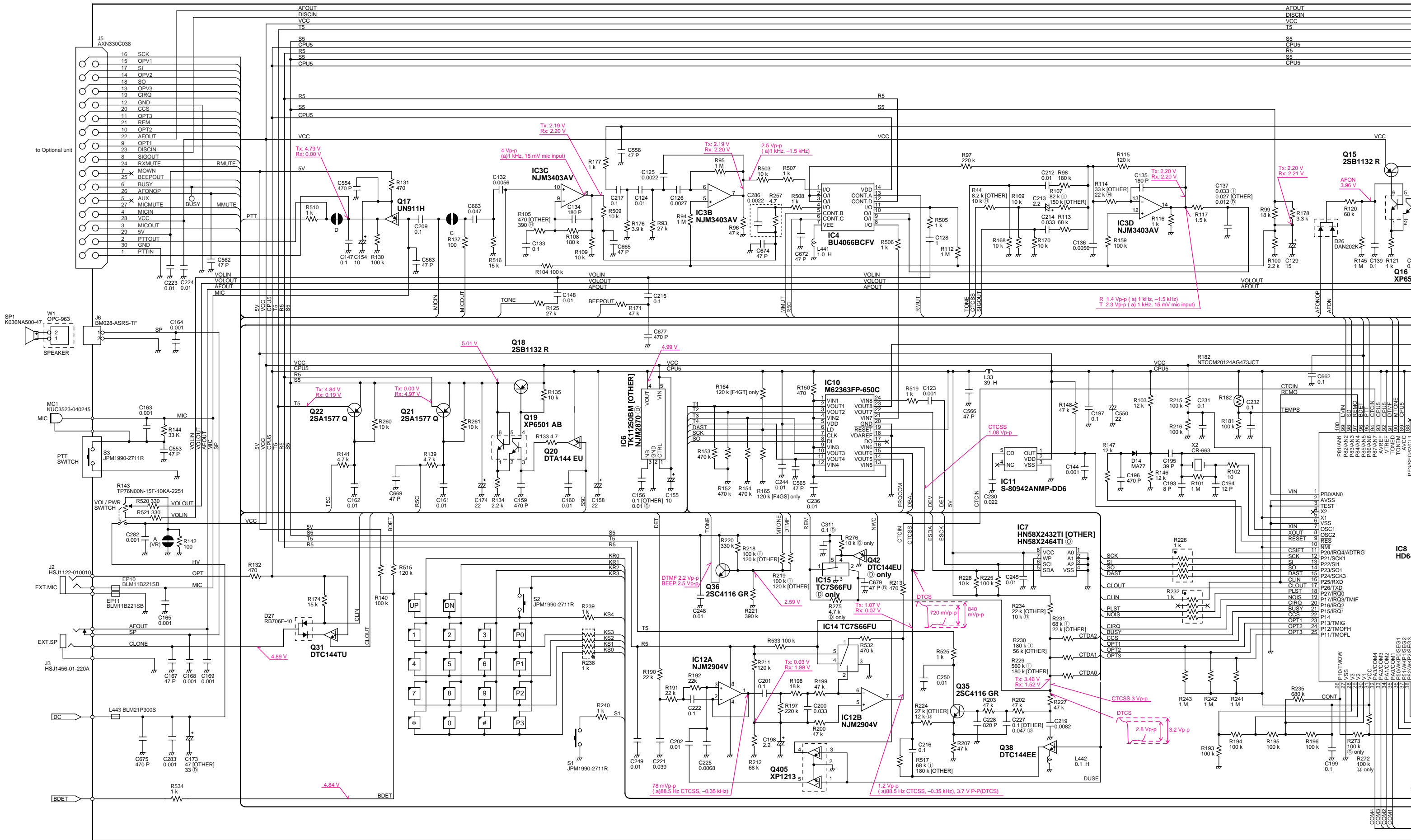

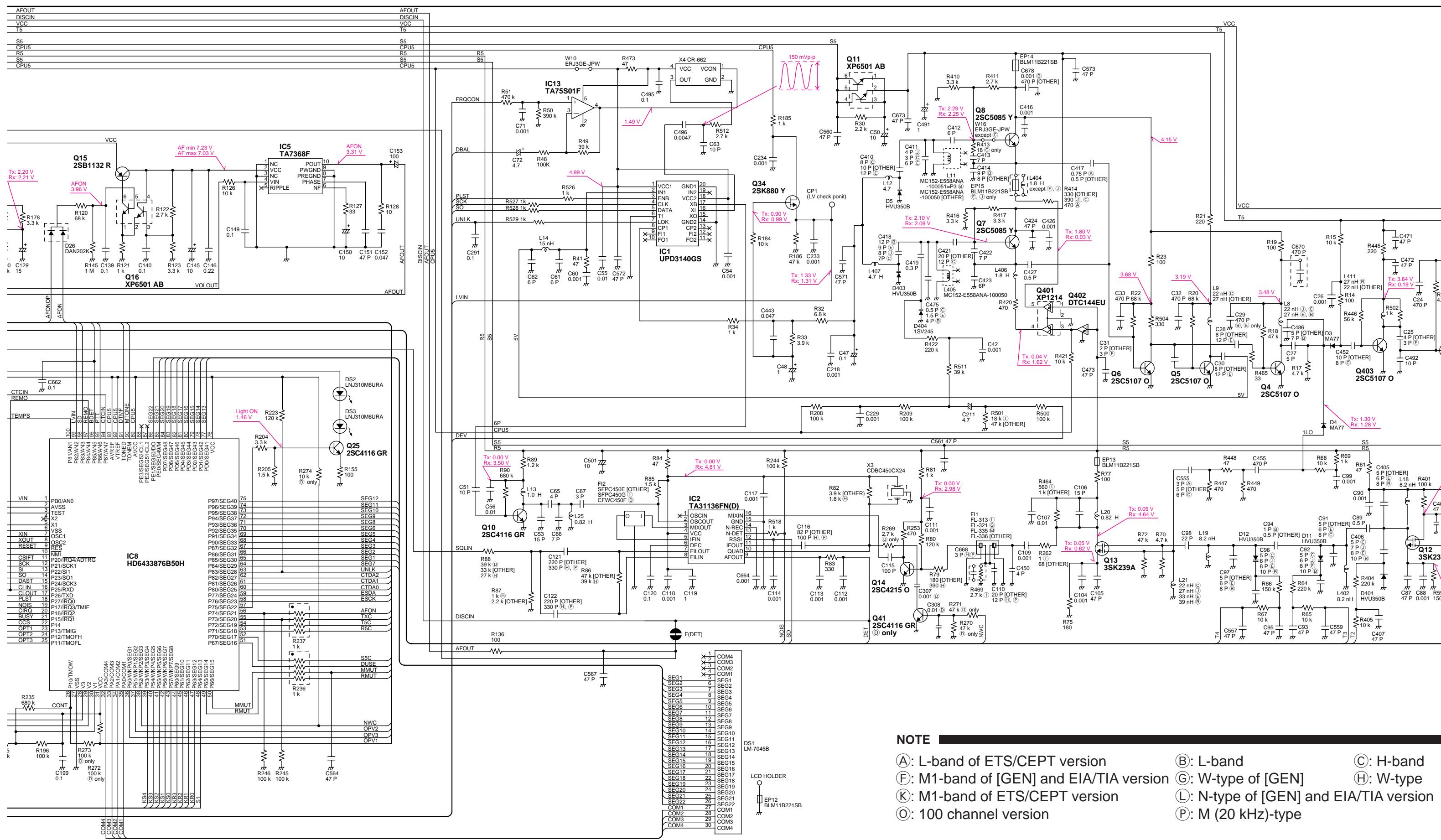

NOTE

(A): L-band of ETS/CEPT version
 (B): L-band
 (C): H-band
 (F): M1-band of [GEN] and EIA/TIA version
 (G): W-type of [GEN]
 (H): W-type
 (K): M1-band of ETS/CEPT version
 (L): N-type of [GEN] and EIA/TIA version
 (O): 100 channel version
 (P): M (20 kHz)-type

1	COM4
2	COM3
3	COM2
4	COM1
5	
6	SEG1
7	SEG2
8	SEG3
9	SEG4
10	SEG5
11	SEG6
12	SEG7
13	SEG8
14	SEG9
15	SEG10
16	SEG11
17	SEG12
18	SEG13
19	SEG14
20	SEG15
21	SEG16
22	SEG17
23	SEG18
24	SEG19
25	SEG20
26	SEG21
27	SEG22
28	COM1
29	COM2
30	COM3
31	COM4

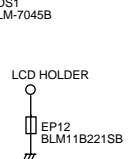

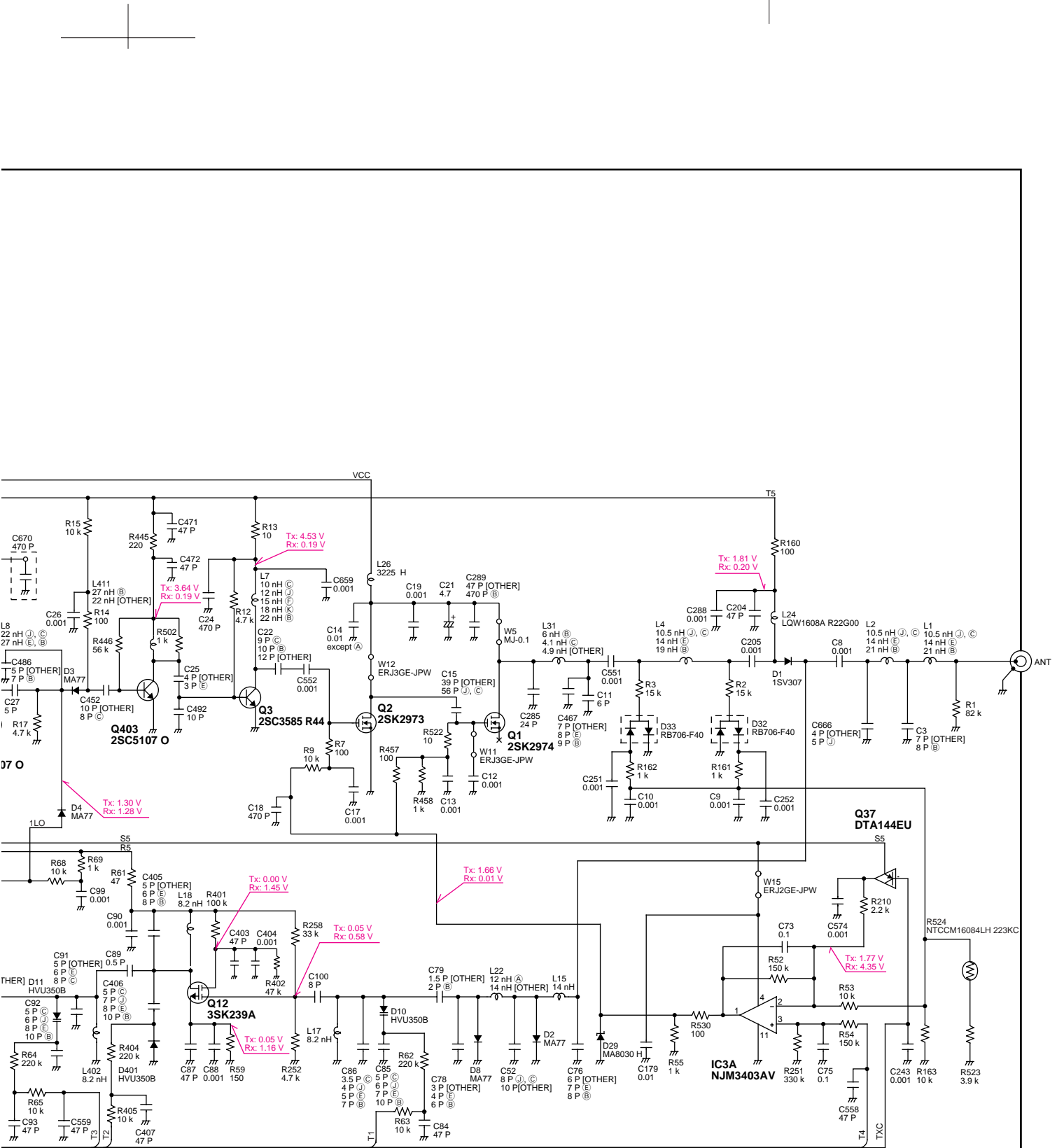

- Ⓢ: H-band
- Ⓜ: W/N-type
- Ⓝ: M1 (440-470 MHz)-band
- Ⓜ: W-type
- Ⓝ: N-type
- Ⓜ: M2 (470-500 MHz)-band
- Ⓜ and Ⓝ: N-type of ETS/CEPT version
- Ⓝ: M1-band except W/N-type

SECTION 12 VOLTAGE DIAGRAM

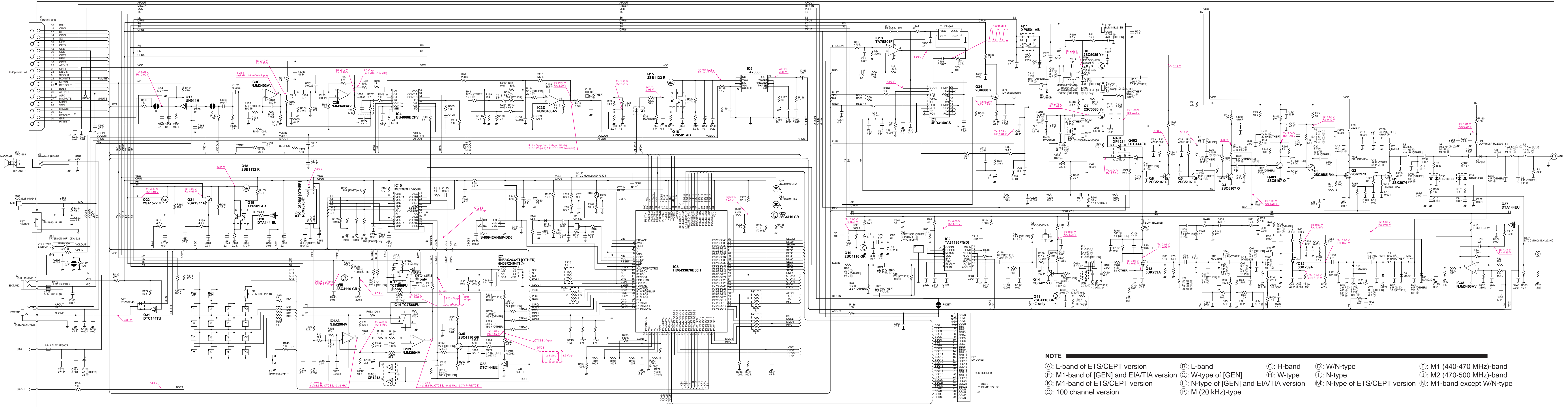

Icom Inc.

1-1-32, Kamiminami, Hirano-ku, Osaka 547-0003, Japan
Phone : +81 (06) 6793 5302
Fax : +81 (06) 6793 0013
URL : <http://www.icom.co.jp/world/index.html>

Icom America Inc.

<Corporate Headquarters>
2380 116th Avenue N.E., Bellevue, WA 98004, U.S.A.
Phone : +1 (425) 454-8155 Fax : +1 (425) 454-1509
URL : <http://www.icomamerica.com>
E-mail : sales@icomamerica.com
<Customer Service>
Phone : +1 (425) 454-7619

Icom Canada

Glenwood Centre #150-6165
Highway 17 Delta, B.C., V4K 5B8, Canada
Phone : +1 (604) 952-4266 Fax : +1 (604) 952-0090
URL : <http://www.icomcanada.com>
E-mail : info@icomcanada.com

Icom (Australia) Pty. Ltd.

A.B.N. 88 006 092 575
290-294 Albert Street, Brunswick, Victoria, 3056, Australia
Phone : +61 (03) 9387-0666 Fax : +61 (03) 9387-0022
URL : <http://www.icom.net.au>
E-mail : sales@icom.net.au

Icom New Zealand

146A Harris Road, East Tamaki,
Auckland, New Zealand
Phone : +64 (09) 274 4062 Fax : +64 (09) 274 4708
URL : <http://www.icom.co.nz>
E-mail : inquiries@icom.co.nz

Beijing Icom Ltd.

1305, Wanshang Plaza, Shijingshan Road, Beijing China
Phone : +86 (010) 6866 6337 Fax : +86 (010) 6866 3553
URL : <http://www.bjicom.com>
E-mail : bjicom@bjicom.com

Icom (Europe) GmbH

Communication Equipment
Himmelgeister Str. 100, D-40225 Düsseldorf, Germany
Phone : +49 (0211) 346047 Fax : +49 (0211) 333639
URL : <http://www.icomeurope.com>
E-mail : info@icomeurope.com

Icom Spain S.L

Crta. de Gracia a Manresa Km. 14.750
08190 Sant Cugat del Valles Barcelona, SPAIN
Phone : +34 (93) 590 26 70 Fax : +34 (93) 589 04 46
URL : <http://www.icomspain.com>
E-mail : icom@icomspain.com

Icom (UK) Ltd.

Unit 9, Sea St., Heme Bay, Kent, CT6 8LD, U.K.
Phone : +44 (01227) 741741 Fax : +44 (01227) 741742
URL : <http://www.icomuk.co.uk>
E-mail : info@icomuk.co.uk

Icom France S.a

Zac de la Plaine, 1, Rue Brindejonc des Moulinais
BP 5804, 31505 Toulouse Cedex, France
Phone : +33 (5) 61 36 03 03 Fax : +33 (5) 61 36 03 00
URL : <http://www.icom-france.com>
E-mail : icom@icom-france.com

Asia Icom Inc.

6F No.68, Sec. 1 Cheng-Teh Road, Taipei, Taiwan, R.O.C.
Phone : +886 (02) 2559 1899 Fax : +886 (02) 2559 1874
URL : <http://www.asia-icom.com>
E-mail : sales@asia-icom.com

Icom Polska

Sopot, 3 Maja 54 Poland
Phone : +48 (58) 550 7135 Fax : +48 (58) 551 0484
E-mail : icompolaska@icompolaska.com.pl

Count on us!

Icom Inc.

1-1-32, Kamiminami, Hirano-ku, Osaka, 547-0003, Japan

S-13713IZ-C1U-①

© 2000 Icom Inc.